

# PURA

## Technical-Info

APRIL 2019

The logo for Loran, featuring the word "Loran" in a bold, italicized sans-serif font. Below the "L" is a horizontal line that extends to the right and then curves upwards. Below the word "Loran" is the tagline "everyday passion" in a smaller, lowercase sans-serif font.

**Loran**  
everyday passion

## MODULI

Aggiungere ad ogni elemento il prezzo del supporto a pavimento o del basamento e relativi fianchi laterali dove necessari, del piano, dell'alzatina, del lavello e del rubinetto.

I moduli su misura possono essere realizzati solo con anta: applicare il prezzo dell'articolo di misura superiore con un supplemento del 25%.

## ATTENZIONE

Indicare sempre le misure delle apparecchiature che devono essere inserite nei moduli.

Le composizioni si intendono sempre a partire da sinistra verso destra. Specificare i colori di fianchi e frontali.

## PER COLORI STANDARD SI INTENDE:

- Bianco Loran per i frontali, i fianchi di finitura e i basamenti
- Bianco Loran per il cassetto estraibile/frontale fisso sottopiano.

Specificare dimensioni e tipo di piano, alzatina, lavello e rubinetto.

Per composizioni con elementi ad angolo verificare la perpendicolarità delle pareti (90°): considerando la distanza di 80 cm. su una parete e 60 cm. sull'altra, la diagonale deve corrispondere a 100 cm.

Dimensioni: L = Larghezza P = Profondità H = Altezza

## MANIGLIE ALLUMINIO

N.B.: solo in alluminio, **NO** verniciate.

## SUPPORTI A PAVIMENTO

N.B.: piedi solo in alluminio, **NO** verniciati.

**CORIAN®, STRATIFICATO E LAMINATO FENIX®:** solo di colore bianco.

**INOX AISI 304:** satinato.

## MAGGIORAZIONI DI PREZZO PER COLORAZIONI SPECIALI

- RAL standard:

Supplemento coppia fianchi di finitura	+ 90,00 €
Supplemento serie frontali/anta (ogni mobile)	+ 90,00 €
Basamento (ogni mobile)	+ 30,00 €
Frontale fisso/estraibile	+ 30,00 €

- RAL metallizzati/perlati e brillanti e in altri colori diversi dalla cartella RAL:

Supplemento coppia fianchi di finitura	+ 180,00 €
Supplemento serie frontali/anta (ogni mobile)	+ 180,00 €
Basamento (ogni mobile)	+ 60,00 €
Frontale fisso/estraibile	+ 60,00 €

**SPESE IMBALLO:** ogni collo € 15,00 prezzo netto.

## UNITS

Add the price of the floor support or base, sides, top, splashback, sink and mixer to each unit.

Made-to-measure units: apply the price of the item with the next greater size and add a 25% extra charge.

## ATTENTION

Always provide the dimensions of the appliances that will be inserted into the units.

The compositions are always understood as starting from the left to the right.

Specify the colors of the sides and fronts.

## STANDARD COLORS:

- Bianco Loran / White Loran for sides and fronts, sides and bases.
- Bianco Loran / White Loran for the undercounter pull-out drawer /fixed front.

Specify the dimensions and type of top, splashback, sink and mixer.

Straight compositions with technical raceway and sink: use tops with minimum depth 520 mm.

For compositions with corner elements check that the walls are perfectly perpendicular (90°): considering the distance of 80 cm on the right and 60 cm left hand sides of the corner, the diagonal line must be 100 cm.

Dimensions:

L = Width P = Depth H = Height

## ALUMINIUM HANDLE

Attention: only aluminium, **NOT** painted.

## FLOOR SUPPORT

Attention: only aluminium feet, **NOT** painted.

**CORIAN®, STRATIFIED and LAMINATE FENIX®:** only in white color.

**INOX AISI 304:** satin finish.

## UPCHARGES FOR SPECIAL COLORS

- Standard RAL:

Sides (2x): upcharge + 90,00 €  
 Fronts/door: upcharge for each unit + 90,00 €  
 Base: upcharge for each unit +30,00 €  
 Fixed/pull-out front + 30,00 €

- Metallized/pearl and luminous RAL colors and other different colors from the RAL colors:

Sides (2x): upcharge + 180,00 €  
 Fronts/door: upcharge for each unit + 180,00 €  
 Base: upcharge for each unit + 60,00 €  
 Fixed/pull-out front + 60,00 €

## PACKING COSTS:

each package € 15,00 net price.

## Colori RAL consigliati per il cassetto estraibile / frontale fisso sottopiano

Recommended RAL colours for the removable drawer / under-counter fixed front item

Coloris RAL conseillés pour le tiroir extractible / façade fixe sous plan

Empfohlene RAL-Farben für ausziehbare Schublade / feststehende Front Unterbau

Colores RAL recomendados para el cajón extraíble / frente fijo de la pieza debajo de la encimera



RAL 1028



RAL 3016



RAL 6018



BIANCO LORAN

## MODULES

À chaque module il faut ajouter le prix de : support au sol, base et cotés, plan, dossier, évier et robinet.

Les modules sur mesure peuvent être réalisés uniquement avec une porte: appliquer le prix de l'article de mesure supérieure et ajouter un supplément de 25%.

## ATTENTION

Indiquer obligatoirement les mesures exactes des appareils destinés à être introduits dans les meubles.

Les compositions s'entendent toujours en partant de gauche vers la droite.

Spécifier les couleurs des panneaux latéraux et des façades.

## COULEURS STANDARD:

- Blanc Loran pour les côtés, les façades et les bases.
- Blanc Loran pour le tiroir extractible/ façade fixe sous plan.

Spécifier les dimensions et le type du plan, du dossier, du lavabo et du robinet. Pour les compositions avec des éléments d'angle, contrôler soigneusement la perpendicularité des murs (90°): si on prend la distance exacte de 80 cm à droite et 60 cm à gauche de l'angle, la diagonale devra mesurer 100 cm.

Dimensions:

L = Largeur P = Profondeur H = Hauteur

## POIGNÉE EN ALUMINIUM

Attention: en aluminium, PAS peintes.

## SUPPORTS AU SOL

Attention: pieds en aluminium, PAS peints.

**CORIAN®, STRATIFIE' et LAMINE' FENIX®: en couleur blanc seulement.**

**INOX AISI 304: satiné.**

## SUPPLÉMENTS DE PRIX POUR COULEURS SPÉCIALES

### • RAL standard:

Côtés (2x) : supplément de prix + 90,00 €  
Façades/porte: supplément de prix pour chaque module + 90,00 €  
Base: supplément de prix pour chaque module + 30,00 €  
Façade fixe/extractible supplément de prix +30,00 €

### • Couleurs RAL métallisés/pearl et lumineux et d'autres couleurs différentes des couleurs RAL:

Côtés (2x) : supplément de prix + 180,00 €  
Façades/porte: supplément de prix pour chaque module + 180,00 €  
Base: supplément de prix pour chaque module + 60,00 €  
Façade fixe/extractible: supplément de prix + 60,00 €

## FRAIS D'EMBALLAGE:

prix net de chaque colis € 15,00.

## SCHRÄNKE

Bei jedem Element muss der Preis des Bodengestells oder Sockels und, gegebenenfalls, der jeweiligen Seiten der Ebene, der Aufkantung, des Waschbeckens und des Wasserhahns separat berechnet werden.

Maßgefertigte Module können nur mit Tür hergestellt werden: auf den Preis des nächst größeren Artikels einen Mehrpreis von 25% berechnen.

## VORSICHT

Immer die Maße der Geräte angeben, die in die Module eingebaut werden sollen.

Die Anbaulösungen sind immer von links nach rechts angegeben.

Die Farben der Seiten und Fronten angeben.

## STANDARD FARBEN:

- Loran Weiss für Seiten, Fronten und Sockel.
- Loran Weiss für ausziehbare Schublade/ feststehende Front Unterbau.

Abmessungen und Art der Ebene, Aufkantung, Waschbecken und Wasserhahn angeben.

Bei Anbaulösungen mit Eckelementen lotrechte (90°) Wände kontrollieren: bei einem Abstand von 80 cm an einer Wand und 60 cm an der anderen von der Ecke muss die Diagonale 100 cm betragen.

Abmessungen: L = Breite P = Tief H = Höhe

## ALUMINIUMGRIFF

Bitte beachten: Aluminium, NICHT lackiert.

## BODENGESTELL

Bitte beachten: Aluminiumfüße, NICHT lackierte.

**CORIAN®, SCHICHTSTOFF und LAMINAT FENIX®: nur weiß.**

**EDELSTAHL 304: satinert**

## AUFPREIS FÜR SONDERFARBEN

### • Standard RAL:

Zierseiten (2x): Aufpreis + 90,00 €  
Fronten/Tür: Aufpreis für jedes Möbelstück + 90,00 €  
Sockel Aufpreis für jedes Möbelstück + 30,00 €  
Feststehende/ausziehbare Front: Aufpreis: +30,00 €

### • Metallic/Perl und leuchtende RAL-Farben und anderen verschiedenen Farben der RAL-Farben:

Zierseiten (2x) : Aufpreis + 180,00 €  
Fronten/Tür: Aufpreis für jedes Möbelstück + 180,00 €  
Sockel: Aufpreis für jedes Möbelstück + 60,00 €  
Feststehende/ausziehbare Front: Aufpreis: +60,00 €

## VERPACKUNGSKOSTEN:

jedes Paket € 15,00 Nettopreis.

## MÓDULOS

Añadir a cada elemento el precio del soporte de pie, o de la base y de los paneles laterales, de la encimera, de la alzada, del lavabo y del grifo.

Los muebles a medida pueden realizarse sólo con la puerta: aplicar el precio del artículo de medida superior con un recargo del 25%.

## ATENCIÓN

Indicar siempre las medidas de los equipos que deben introducirse en los módulos.

Las composiciones se consideran siempre a partir de la izquierda hacia la derecha.

Especificar los colores de los paneles laterales y de los frentes.

## COLORES ESTANDAR:

- Blanco Loran para los paneles laterales, los frentes y las bases.
- Blanco Loran para el cajón extraíble/ frente fijo de la pieza debajo de la encimera.

Especificar las dimensiones y el tipo de encimera, de alzada, de lavabo y de grifo. Para composiciones con elementos en ángulo controlar la perpendicularidad de las paredes (90°): considerando la distancia de 80 cm a la dcha. y 60 cm a la izq. del ángulo, la diagonal debe corresponder a 100 cm.

Dimensiones:

L = Ancho P = Profundidad H = Alto

## TIRADOR DE ALUMINIO

Atención: en aluminio, NO pinta.

## SOPORTE DE PIE

Atención: patas en aluminio, NO pintadas.

**CORIAN®, ESTRATIFICADO y LAMINADO FENIX®: de color blanco.**

**INOX AISI 304: satinado.**

## CARGOS ADICIONAL PARA COLORACIONES ESPECIALES

### • RAL estándar:

Laterales (2x): cargo adicional + € 90,00  
Frentes/puerta: cargo adicional por cada módulo + € 90,00  
Base: cargo adicional por cada módulo + € 30,00

### • Frente fijo/extraíble + € 30,00

### • RAL metalizados/perla y brillantes y otros colores diferentes de colores RAL:

Laterales (2x): cargo adicional + € 180,00  
Frentes/puerta: cargo adicional por cada módulo + € 180,00  
Base: cargo adicional por cada módulo + € 60,00  
Frente fijo/extraíble + € 60,00

## EMBALAJE:

cada paquete € 15,00 precio neto.

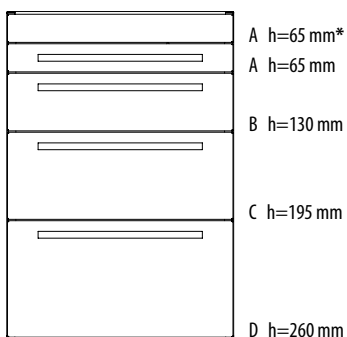
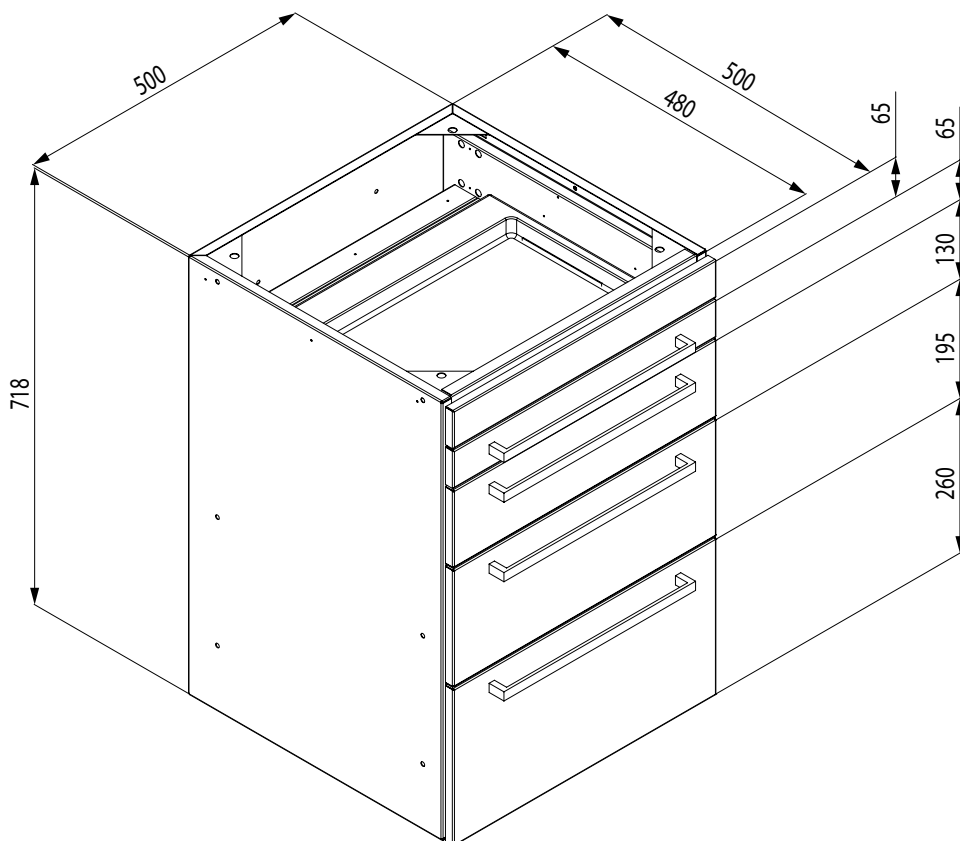

**Cassetti**  
Drawers / Tiroirs  
Schubladen / Cajones

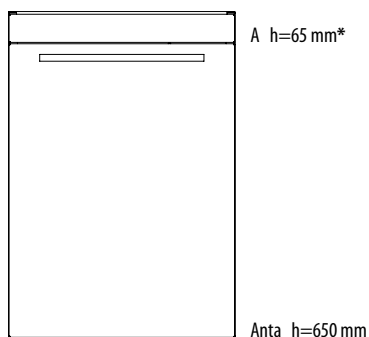

**Anta**  
Door / Porte  
Tür / Puerta

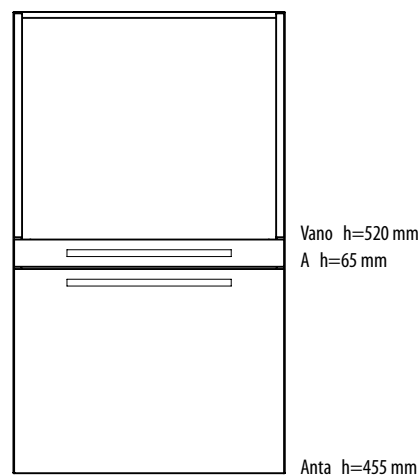

**Modulo per termosigillatrice**  
Lowered module for autoclave  
Module surbaissé pour autoclave  
Gesenktes Modul für Autoklav  
Módulo bajo para autoclave

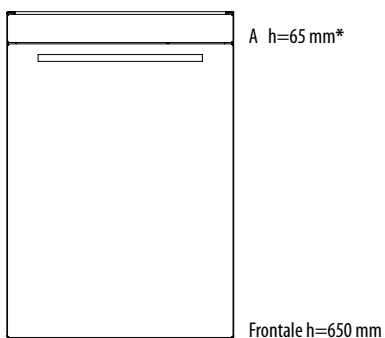

**Cassettone**  
Pullout drawer / Grand tiroir  
Oder schublade / Cajon

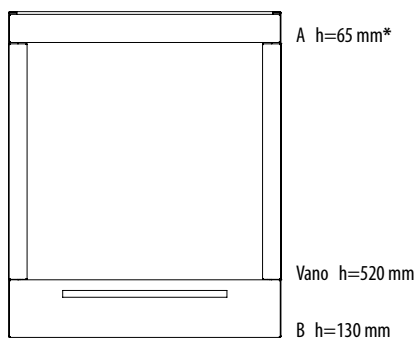

**Modulo per autoclave**  
Module for autoclave / Module pour autoclave  
Modul für Autoklav / Módulo para autoclave

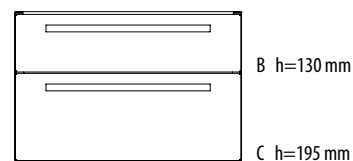

**Modulo per termosigillatrice**  
Module for thermosigilator /  
Module pour thermoscelléuse / Modul für Wärmeversiegelung / Módulo para termoselladora

\* Frontale A fisso (possibilità di sostituzione con cassetto estraibile) / Fixed A front panel (possibility of replacement with pull-out shelf) / Façade A fixe (possibilité de la remplacer par un tiroir extractible) / Feststehende Frontseite A (austauschbar mit ausziehbarer Schublade) / Frente A fijo (posibilidad de sustitución con cajón extraíble)

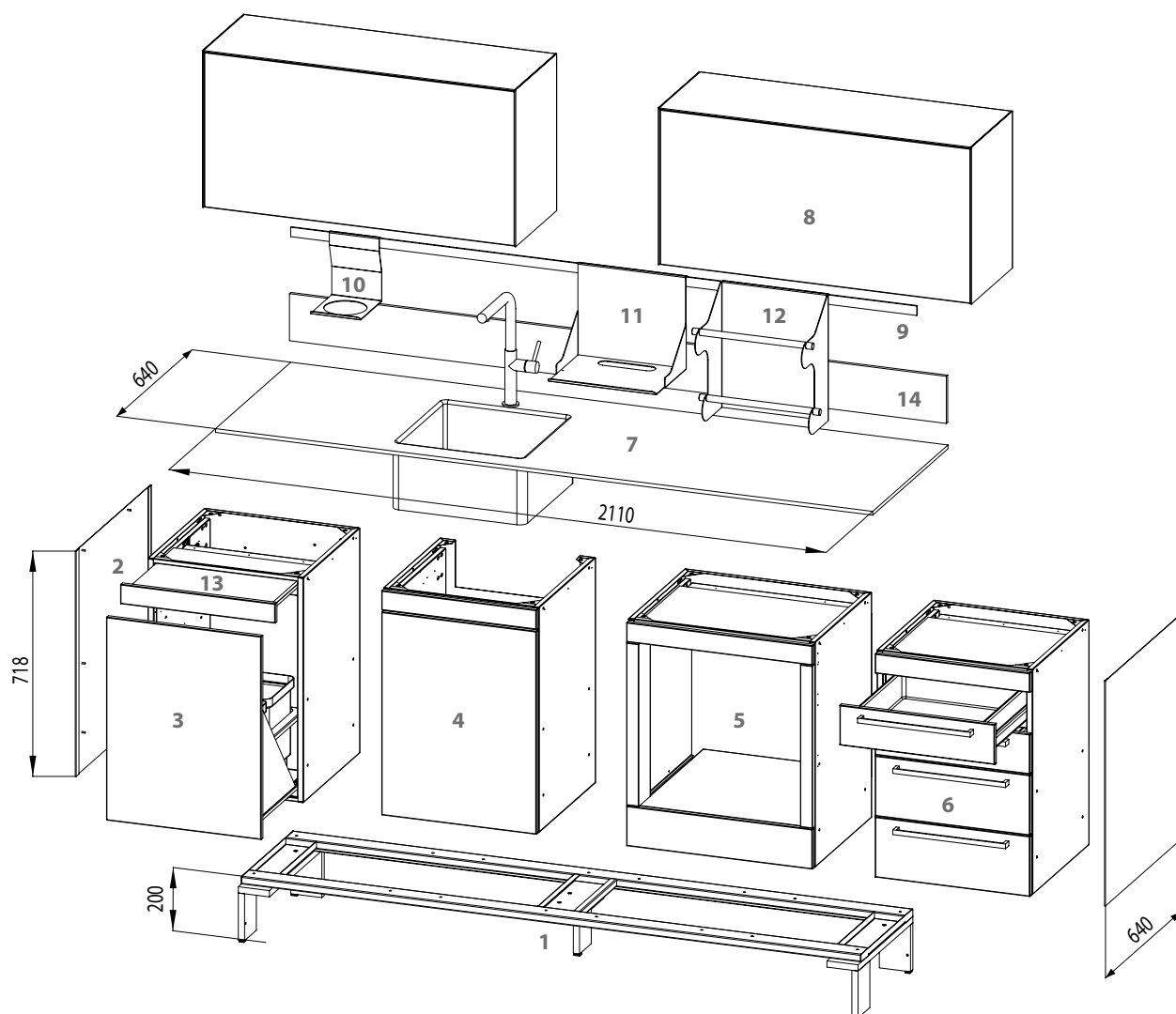

## MOBILE PURA

**1** - Supporto a pavimento; **2** - Fianco laterale; **3** - Mobile con cassettone estraibile; **4** - Mobile lavello; **5** - Mobile porta autoclave; **6** - Mobile con 4 cassetti: 2 B e 2 C; **7** - Piano con lavello; **8** - Pensile; **9** - Barra attrezzata; **10** - Supporto contenitore aghi; **11** - Supporto attrezzatura; **12** - Portarotolo da esterno; **13** - Ripiano estraibile; **14** - Alzatina.

## UNIT PURA

**1** - Floor support; **2** - Lateral side; **3** - Module with large pull-out drawer; **4** - Sink unit; **5** - Module for autoclave; **6** - Unit with 4 drawers: 2 B and 2 C; **7** - Top with sink; **8** - Wall unit; **9** - Equipped bar; **10** - Support for needle container; **11** - Support for equipments; **12** - Roll holder for exterior; **13** - Pull-out shelf; **14** - Splashback.

## MOBILIER PURA

**1** - Support au sol; **2** - Panneau latéral; **3** - Module avec bac extractible; **4** - Module lavabo; **5** - Module pour autoclave; **6** - Module avec 4 tiroirs: 2 B + 2 C; **7** - Plan avec évier; **8** - Élément mural; **9** - Barre équipée; **10** - Support pour conteneur à aiguilles; **11** - Support pour équipements; **12** - Porte-rouleau extérieur; **13** - Tirette; **14** - Dossieret.

## PURA-MÖBEL

**1** - Bodengestell; **2** - Seitenwand; **3** - Modul mit ausziehbarer Schublade; **4** - Waschbeckenschrank; **5** - Modul für Autoklav; **6** - Schrank mit 4 Schubladen: 2 B + 2 C; **7** - Arbeitsplatte mit Waschbecken; **8** - Hängeschrank; **9** - Stangenausstattung; **10** - Halterung für Nadelbehälter; **11** - Halterung für Geräte; **12** - Rollenhalterung für außen; **13** - Ausziehbarer Einlegeboden; **14** - Aufkantung.

## MUEBLE PURA

**1** - Soporte de pie; **2** - Panel lateral; **3** - Módulo con cajón extraíble; **4** - Módulo bajo lavabo; **5** - Módulo para autoclave; **6** - Módulo con 4 cajones: 2 B + 2 C; **7** - Encimera con lavabo; **8** - Mueble colgante; **9** - Barra equipada; **10** - Soporte para contenedor agujas; **11** - Soporte para equipos; **12** - Porta-rollos para exterior; **13** - Estante extraíble; **14** - Alzada.

H Sottopiano: / H Under the top: / H Sous plan de travail: / H Unter der Arbeitsplatte: / A Bajo encimera: 920 mm

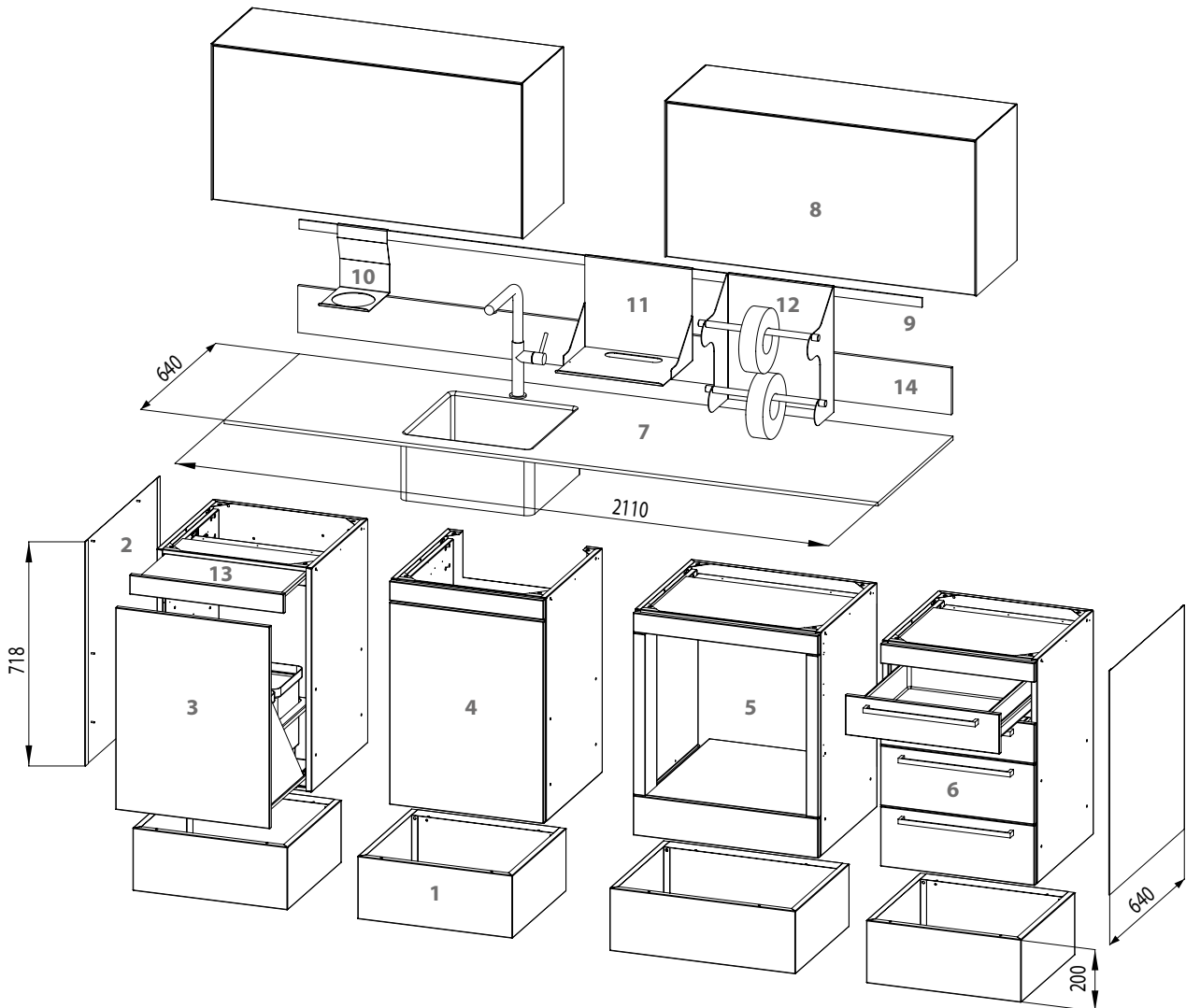

## MOBILE PURA

1 - Basamento; 2 - Fianco laterale; 3 - Mobile con cassettone estraibile; 4 - Mobile lavello; 5 - Mobile porta autoclave; 6 - Mobile con 4 cassetti: 2 B e 2 C; 7 - Piano con lavello; 8 - Pensile; 9 - Barra attrezzata; 10 - Supporto contenitore aghi; 11 - Supporto attrezzatura; 12 - Portarotolo da esterno; 13 - Ripiano estraibile; 14 - Alzatina.

## UNIT PURA

1 - Base unit; 2 - Lateral side; 3 - Module with large pull-out drawer; 4 - Sink unit; 5 - Module for autoclave; 6 - Unit with 4 drawers: 2 B and 2 C; 7 - Top with sink; 8 - Wall unit; 9 - Equipped bar; 10 - Support for needle container; 11 - Support for equipments; 12 - Roll holder for exterior; 13 - Pull-out shelf; 14 - Splashback.

## MOBILIER PURA

1 - Base; 2 - Panneau latéral; 3 - Module avec bac extractible; 4 - Module lavabo; 5 - Module pour autoclave; 6 - Module avec 4 tiroirs: 2 B + 2 C; 7 - Plan avec évier; 8 - Élément mural; 9 - Barre équipée; 10 - Support pour conteneur à aiguilles; 11 - Support pour équipements; 12 - Porte-rouleau extérieur; 13 - Tirette; 14 - Dossieret.

## PURA-MÖBEL

1 - Sockel; 2 - Seitenwand; 3 - Modul mit ausziehbarer Schublade; 4 - Waschbeckenschrank; 5 - Modul für Autoklav; 6 - Schrank mit 4 Schubladen: 2 B + 2 C; 7 - Arbeitsplatte mit Waschbecken; 8 - Hängeschrank; 9 - Stangenausstattung; 10 - Halterung für Nadelbehälter; 11 - Halterung für Geräte; 12 - Rollenhalterung für außen; 13 - Ausziehbarer Einlegeboden; 14 - Aufkantung.

## MUEBLE PURA

1 - Base; 2 - Panel lateral; 3 - Módulo con cajón extraíble; 4 - Módulo bajo lavabo; 5 - Módulo para autoclave; 6 - Módulo con 4 cajones: 2 B + 2 C; 7 - Encimera con lavabo; 8 - Mueble colgante; 9 - Barra equipada; 10 - Soporte para contenedor agujas; 11 - Soporte para equipos; 12 - Porta-rollos para exterior; 13 - Estante extraíble; 14 - Alzada.

H Sottopiano: / H Under the top: / H Sous plan de travail: / H Unter der Arbeitsplatte: / A Bajo encimera: 920 mm

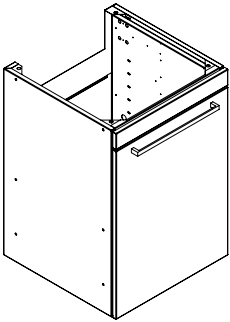
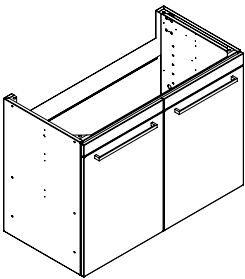
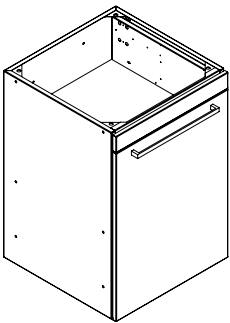
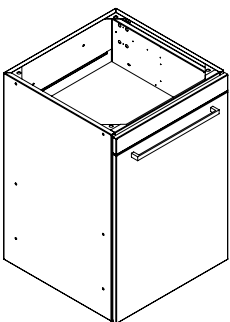
	<b>Descrizione / Description</b> Description / Beschreibung / Descripción	<b>Apertura</b> Opening / Ouverture Öffnung / Apertura	<b>M<sup>3</sup></b> <b>Kg</b>	<b>Articolo</b> Item / Article Artikel / Artículo		
 <p><b>L 500 x P 500 x H 718 mm</b></p>	<p><b>MODULO sottolavello con anta "PLA" o con cassettone estraibile "PLC", con portarifiuti interno</b></p> <p>Sink module with "PLA" door or "PLC" pullout drawer, with internal waste bin</p> <p>Module évier avec porte "PLA" ou avec bac extractible "PLC", avec poubelle intérieure</p> <p>Unterwaschbecken-Modul mit Tür "PLA" oder ausziehbarer Schublade "PLC", mit Innenabfallbehälter</p> <p>Módulo debajo del lavabo con hoja "PLA" o con cajón extraíble "PLC", con cubo de basura interior</p>	<p>Maniglia Handle Poignée Griff Tirador</p>	0,17	PLAM		
			27,7			
		<p>Push-Pull</p>			0,17	PLCM
					32,2	
					27,5	
0,17	PLAP					
32	PLCP					
 <p><b>L 1000 x P 500 x H 718 mm</b></p>	<p><b>MODULO sottolavello L 1000 mm con 2 ante e portarifiuti interno</b></p> <p>Sink module sink L 1000 mm with 2 doors and internal waste bin</p> <p>Module évier L 1000 mm avec 2 portes et poubelle intérieure</p> <p>Unterwaschbecken-Modul L 1000 mm mit 2 Türen und Innenabfallbehälter</p> <p>Módulo debajo del lavabo L 1000 mm con 2 hojas y cubo de basura interior</p>	<p>Maniglia Handle Poignée Griff Tirador</p>	0,36	PLLMM		
			48,4			
		<p>Push-Pull</p>			0,36	PLLPL
					48	
 <p><b>L 500 x P 500 x H 718 mm</b> <b>L 600 x P 500 x H 718 mm</b></p>	<p><b>MODULO con anta e due ripiani interni</b></p> <p>Unit with door and 2 interior shelves</p> <p>Module avec porte et 2 étagères internes</p> <p>Schrank mit Tür und 2 Einlegeböden</p> <p>Módulo con puerta y dos estantes interiores</p>	<p>Maniglia Handle Poignée Griff Tirador</p>	0,17	PPAM (L. 500 mm)		
			26,5			
		<p>Push-Pull</p>			0,22	PPMM (L. 600 mm)
					30,5	
					0,17	
26,3	PPAP (L. 500 mm)					
0,22	PPMP (L. 600 mm)					
30,3						
 <p><b>L 500 x P 500 x H 718 mm</b> <b>L 600 x P 500 x H 718 mm</b></p>	<p><b>MODULO schiena aperta, con anta e due ripiani interni</b></p> <p>Open back module, with door and two internal shelves</p> <p>Module ouvert derrière, avec porte et deux étagères intérieures</p> <p>Modul hinten offen, mit Tür und zwei Einlegeböden</p> <p>Módulo sin paneles, con hoja y dos estantes interiores</p>	<p>Maniglia Handle Poignée Griff Tirador</p>	0,17	PPFM (L. 500 mm)		
			24,3			
		<p>Push-Pull</p>			0,22	PPNM (L. 600 mm)
					28,3	
					0,17	
24,1	PPFP (L. 500 mm)					
28,1	PPNP (L. 600 mm)					

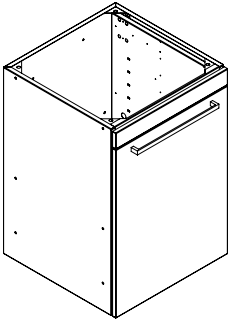
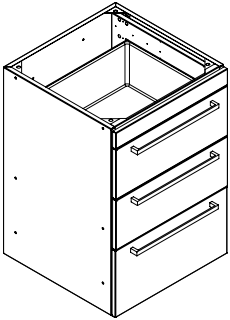
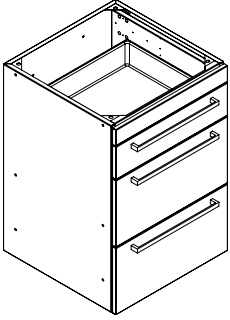
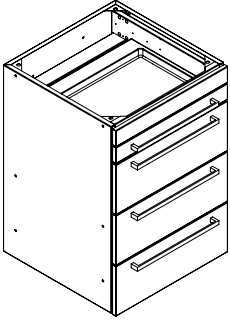
	<b>Descrizione / Description</b> Description / Beschreibung / Descripción	<b>Apertura</b> Opening / Ouverture Öffnung / Apertura	<b>M<sup>3</sup></b> <b>Kg</b>	<b>Articolo</b> Item / Article Artikel / Artículo
 <p><b>L 500 x P 500 x H 718 mm</b></p>	<p><b>MODULO con anta senza ripiani "PPI" o con cassettone estraibile con 3 portarifiuti "PPC"</b></p> <p>Module with "PPI" door without shelves or "PPC" large pull-out drawer with 3 waste bins</p> <p>Module avec porte "PPI" sans étagères ou avec bac extractible avec 3 poubelles "PPC"</p> <p>Modul mit Tür "PPI" ohne Einlegeböden "PPI" oder mit ausziehbarer Schublade mit 3 Abfallbehältern "PPC"</p> <p>Módulo con hoja sin estantes "PPI" o con cajón extraíble con 3 cubos de basura "PPC"</p>		0,17	PPIM
			26,5	
		<b>Anta</b> Door/Porte Tür/Puerta	0,17	PPIP
			26,3	
			0,17	PPCM
			39	
		<b>Cassettone</b> Drawer/Tiroir Schublade Cajon	0,17	PPCP
			38,8	
 <p><b>L 500 x P 500 x H 718 mm</b></p>	<p><b>MODULO con 3 cassetti: 2 C e 1 D</b></p> <p>Unit with 3 drawers: 2 C and 1 D</p> <p>Module avec 3 tiroirs: 2 C et 1 D</p> <p>Schrank mit 3 Schubladen: 2 C et 1 D</p> <p>Módulo con 3 cajones: 2 C y 1 D</p> <p><b>Bacinelle / Trays / Intérieurs de tiroir</b> <b>Einsätze / Bandejas:</b> <b>3xLBC1</b></p>		0,17	P3AM
			40	
		<b>Maniglia</b> Handle Poignée Griff Tirador		
			0,17	P3AP
		<b>Push-Pull</b>	39,4	
 <p><b>L 500 x P 500 x H 718 mm</b></p>	<p><b>MODULO con 3 cassetti: 1 B e 2 D</b></p> <p>Unit with 3 drawers: 1 B and 2 D</p> <p>Module avec 3 tiroirs: 1 B et 2 D</p> <p>Schrank mit 3 Schubladen: 1 B et 2 D</p> <p>Módulo con 3 cajones: 1 B y 2 D</p> <p><b>Bacinelle / Trays / Intérieurs de tiroir</b> <b>Einsätze / Bandejas:</b> <b>1xLBB1, 2xLBC1</b></p>		0,17	P3BM
			40,2	
		<b>Maniglia</b> Handle Poignée Griff Tirador		
			0,17	P3BP
		<b>Push-Pull</b>	40	
 <p><b>L 500 x P 500 x H 718 mm</b></p>	<p><b>MODULO con 4 cassetti: 1 A e 3 C</b></p> <p>Unit with 4 drawers: 1 A and 3 C</p> <p>Module avec 4 tiroirs: 1 A et 3 C</p> <p>Schrank mit 4 Schubladen: 1 A et 3 C</p> <p>Módulo con 4 cajones: 1 A y 3 C</p> <p><b>Bacinelle / Trays / Intérieurs de tiroir</b> <b>Einsätze / Bandejas:</b> <b>1xLBA2, 3xLBC1</b></p>		0,17	P4AM
			43,7	
		<b>Maniglia</b> Handle Poignée Griff Tirador		
			0,17	P4AP
		<b>Push-Pull</b>	43,5	

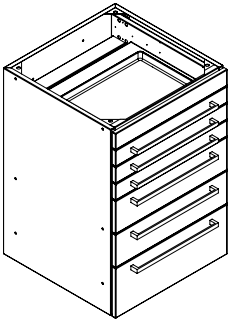
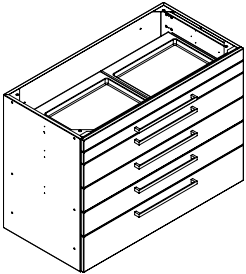
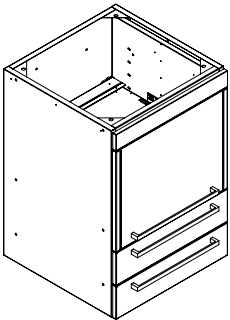

	<b>Descrizione / Description</b> Description / Beschreibung / Descripción	<b>Apertura</b> Opening / Ouverture Öffnung / Apertura	<b>M<sup>3</sup></b> <b>Kg</b>	<b>Articolo</b> Item / Article Artikel / Artículo
<p><b>MODULO con 4 cassetti: 2 B e 2 C</b> Unit with 4 drawers: 2 B and 2 C Module avec 4 tiroirs: 2 B et 2 C Schrank mit 4 Schubladen: 2 B et 2 C Módulo con 4 cajones: 2 B y 2 C</p> <p><b>Bacinelle / Trays / Intérieurs de tiroir</b> <b>Einsätze / Bandejas:</b> <b>1xLBB1, 1xLBB2, 2xLBC1</b></p> <p><b>L 500 x P 500 x H 718 mm</b></p>		<b>Maniglia</b> Handle Poignée Griff Tirador	0,17 ----- 44,3	P4BM
	Push-Pull	0,17 ----- 44,1	P4BP	
<p><b>MODULO con 4 cassetti: 3 B e 1 D</b> Unit with 4 drawers: 3 B and 1 D Module avec 4 tiroirs: 3 B et 1 D Schrank mit 4 Schubladen: 3 B et 1 D Módulo con 4 cajones: 3 B y 1 D</p> <p><b>Bacinelle / Trays / Intérieurs de tiroir</b> <b>Einsätze / Bandejas:</b> <b>1xLBB1, 1xLBB2, 1xLBB3, 1xLBC1</b></p> <p><b>L 500 x P 500 x H 718 mm</b></p>		<b>Maniglia</b> Handle Poignée Griff Tirador	0,17 ----- 38,5	P4CM
	Push-Pull	0,17 ----- 38,3	P4CP	
<p><b>MODULO con 5 cassetti: 1 A, 3 B e 1 C</b> Unit with 5 drawers: 1 A, 3 B and 1 C Module avec 5 tiroirs: 1 A, 3 B et 1 C Schrank mit 5 Schubladen: 1 A, 3 B et 1 C Módulo con 5 cajones: 1 A, 3 B y 1 C</p> <p><b>Bacinelle / Trays / Intérieurs de tiroir</b> <b>Einsätze / Bandejas:</b> <b>1xLBA2, 1xLBB1, 1xLBB2, 1xLBB3, 1xLBC1</b></p> <p><b>L 500 x P 500 x H 718 mm</b></p>		<b>Maniglia</b> Handle Poignée Griff Tirador	0,17 ----- 48,2	P5AM
	Push-Pull	0,17 ----- 48	P5AP	
<p><b>MODULO con 5 cassetti: 5 B</b> Unit with 5 drawers: 5 B Module avec 5 tiroirs: 5 B Schrank mit 5 Schubladen: 5 B Módulo con 5 cajones: 5 B</p> <p><b>Bacinelle / Trays / Intérieurs de tiroir</b> <b>Einsätze / Bandejas:</b> <b>3xLBB1, 1xLBB2, 1xLBB3</b></p> <p><b>L 500 x P 500 x H 718 mm</b></p>		<b>Maniglia</b> Handle Poignée Griff Tirador	0,17 ----- 48,9	P5BM
	Push-Pull	0,17 ----- 48,7	P5BP	

	<b>Descrizione / Description</b> Description / Beschreibung / Descripción	<b>Apertura</b> Opening / Ouverture Öffnung / Apertura	<b>M<sup>3</sup></b> <b>Kg</b>	<b>Articolo</b> Item / Article Artikel / Artículo
 <p><b>MODULO con 6 cassetti: 3 A, 2 B e 1 C</b> Unit with 6 drawers: 3 A, 2 B and 1 C Module avec 6 tiroirs: 3 A, 2 B et 1 C Schrank mit 6 Schubladen: 3 A, 2 B et 1 C Módulo con 6 cajones: 3 A, 2 B y 1 C</p> <p><b>Bacelle / Trays / Intérieurs de tiroir</b> <b>Einsätze / Bandejas:</b> <b>1xLBA1, 1xLBA2, 1xLBA3, 1xLBB1, 1xLBB3,</b> <b>1xLBC1</b></p> <p><b>L 500 x P 500 x H 718 mm</b></p>		<p><b>Maniglia</b> Handle Poignée Griff Tirador</p>	<p>0,17 ----- 51,6</p>	P6AM
		<p><b>Push-Pull</b></p>	<p>0,17 ----- 51,4</p>	P6AP
 <p><b>MODULO L 1000 mm con 5 cassetti: 1 A, 3 B e 1 C</b> Unit L 1000 mm with 5 drawers: 1 A, 3 B and 1 C Module L 1000 mm avec 5 tiroirs: 1 A, 3 B et 1 C Schrank L 1000 mm mit 5 Schubladen: 1 A, 3 B und 1 C Módulo L 1000 mm con 5 cajones: 1 A, 3 B y 1 C</p> <p><b>Bacelle / Trays / Intérieurs de tiroir</b> <b>Einsätze / Bandejas:</b> <b>2xLBA2, 2XLBB1, 2XLBB2, 2XLBB3, 2XLBC1</b></p> <p><b>L 1000 x P 500 x H 718 mm</b></p>		<p><b>Maniglia</b> Handle Poignée Griff Tirador</p>	<p>0,36 ----- 82</p>	P5AM2
		<p><b>Push-Pull</b></p>	<p>0,36 ----- 81</p>	P5AP2
 <p><b>MODULO con anta a ribalta con 2 ripiani estraibili per apparecchiature + ciabatta con 3 prese di corrente e 2 cassetti B</b> Unit with hide-away door equipped with 2 apparatus storage shelves + 3 Schuko sockets and 2 drawers B Module avec porte basculante avec 2 tirettes pour appareils + 3 prises de courant Schuko et 2 tiroirs B Schrank mit versenkbarer Tür mit 2 Geräteeinlagen + 3 Schuko-Steckdosen und 2 Schubladen B Módulo con puerta plegable con 2 estantes extraíbles para equipos + regleta con 3 tomas de corriente Schuko y 2 cajones B</p> <p><b>Bacelle / Trays / Intérieurs de tiroir</b> <b>Einsätze / Bandejas:</b> <b>1xLBB1, 1xLBB2</b></p> <p><b>L 500 x P 500 x H 718 mm</b></p>		<p><b>Maniglia</b> Handle Poignée Griff Tirador</p>	<p>0,17 ----- 37</p>	PRAM
		<p><b>Push-Pull</b></p>	<p>0,17 ----- 36,4</p>	PRAP

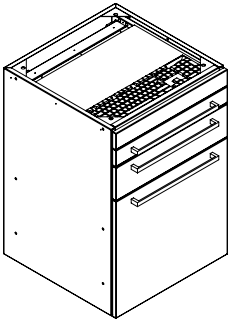
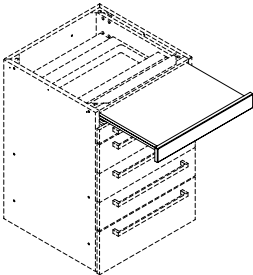
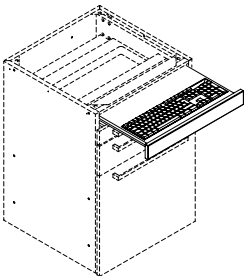
	<b>Descrizione / Description</b> Description / Beschreibung / Descripción	<b>Apertura</b> Opening / Ouverture Öffnung / Apertura	<b>M<sup>3</sup></b> <b>Kg</b>	<b>Articolo</b> Item / Article Artikel / Artículo
 <p><b>MODULO PC con cassetto A per tastiera (L 385 - H 25 mm max) al posto del frontale fisso, 1 cassetto A e 1 B, anta e schiena aperta</b></p> <p>PC module with A drawer for keyboard (L 385 - H 25 mm max), instead of the fixed side, 1 drawer A and 1 B, door and open back</p> <p>Module PC avec tiroir A pour clavier (L 385 - H 25 mm max.), à la place de la façade fixe, 1 tiroir A et 1 B, porte et dossier ouvert</p> <p>PC-modul mit Schublade A für Tastatur (L 385 - H 25 mm max), anstelle der feststehenden Frontseite, 1 Schublade A und 1 B, Tür und Rückseite offen</p> <p>Módulo PC con cajón A para teclado (L 385 - H 25 mm máx), en lugar del frontal fijo, 1 cajón A y 1 B, hoja y abierto en la parte trasera</p> <p><b>Bacinelle / Trays / Intérieurs de tiroir</b> <b>Einsätze / Bandejas: 1xLBA2, 1xLBB1</b></p> <p><b>L 500 x P 500 x H 718 mm</b></p>		<p><b>Maniglia</b> Handle Poignée Griff Tirador</p>	<p>0,17 ----- 42</p>	PPSM
			<p><b>Push-Pull</b></p>	<p>0,17 ----- 41,4</p>
 <p><b>Supplemento per ripiano estraibile Push-Pull in Stratificato o Corian®</b></p> <p>Upcharge for Push-Pull shelf in stratified laminate or Corian®</p> <p>Supplément pour tirette Push-Pull en stratifié ou en Corian®</p> <p>Zusatz für ausziehbaren Push-Pull-Einlegeboden aus Verbundmaterial oder Corian®</p> <p>Suplemento para estante extraíble push-pull de estratificado o corian®</p> <p><b>L 500</b> <b>L 600</b></p>		<p><b>Stratificato</b> Stratifié / Stratifié Schichtstoff Estratificado</p>	<p>- ----- 8,2</p>	<p>PES5 (L. 500 mm)</p>
		<p><b>Corian®</b></p>	<p>- ----- 8,7</p>	<p>PEC5 (L. 500 mm)</p>
		<p><b>Stratificato</b> Stratifié / Stratifié Schichtstoff Estratificado</p>	<p>- ----- 8,7</p>	<p>PES6 (L. 600 mm)</p>
		<p><b>Corian®</b></p>	<p>- ----- 9,2</p>	<p>PEC6 (L. 600 mm)</p>
 <p><b>Supplemento per ripiano estraibile Push-Pull per tastiera (L 385 mm - H 25 mm max)</b></p> <p>Upcharge for removable Push-Pull drawer for keyboard (L 385 mm - H 25 mm max)</p> <p>Supplément pour tirette extractible Push-Pull pour clavier (L 385 mm - H 25 mm max.)</p> <p>Zusatz für ausziehbaren Push-Pull-Einlegeboden für Tastatur (L 385 mm - H 25 mm max)</p> <p>Suplemento para estante extraíble Push-Pull para teclado (L 385 mm - H 25 mm máx)</p> <p><b>L 500</b></p>			<p>- ----- 8,2</p>	<p>PEK5 (L. 500 mm)</p>

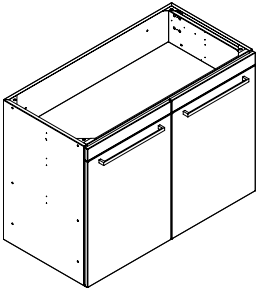
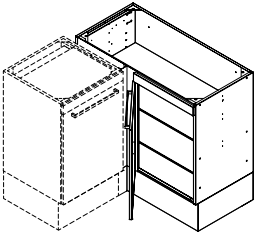
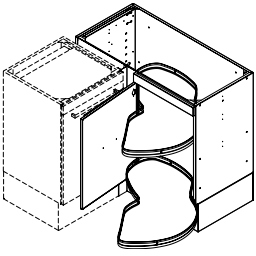
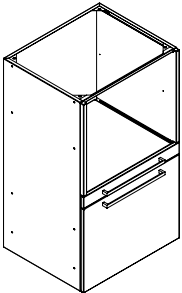
	<b>Descrizione</b> / Description Description / Beschreibung / Descripción	<b>Apertura</b> Opening / Ouverture Öffnung / Apertura	<b>M<sup>3</sup></b> <b>Kg</b>	<b>Articolo</b> Item / Article Artikel / Artículo
 <p><b>L 1000 x P 500 x H 718 mm</b></p>	<p><b>MODULO da 1000 mm con 2 ante e 2 ripiani interni</b></p> <p>1000 mm module with 2 doors and 2 internal shelves</p> <p>Module de 1000 mm avec 2 portes et 2 étagères intérieures</p> <p>Modul 1000 mm, mit 2 Türen und 2 Inneneinlegeböden</p> <p>Módulo de 1000 mm con 2 hojas y 2 estantes interiores</p>	<p>Maniglia Handle Poignée Griff Tirador</p>	<p>0,36 46</p>	PPLM
		<p>Push-Pull</p>	<p>0,36 45,6</p>	
 <p><b>L 1000 x P 500 x H 718 mm</b></p>	<p><b>MODULO angolare con 2 ripiani interni</b></p> <p>Angular module with 2 internal shelves</p> <p>Module d'angle avec 2 étagères intérieures</p> <p>Eckmodul mit 2 Inneneinlegeböden</p> <p>Módulo angular con 2 estantes internos</p>	<p>Maniglia Handle Poignée Griff Tirador</p>	<p>0,36 40</p>	<p>PPOM (Door on the right)</p>
			<p>0,36 40</p>	<p>PPRM (Door on the left)</p>
			<p>0,36 39,8</p>	<p>PPOP (Door on the right)</p>
		<p>Push-Pull</p>	<p>0,36 39,8</p>	<p>PPRP (Door on the left)</p>
 <p><b>L 1000 x P 500 x H 718 mm</b></p>	<p><b>MODULO angolare con 2 ripiani estraibili (portata max 40 kg a ripiano)</b></p> <p>Corner module with 2 pull-out shelves</p> <p>Module d'angle avec 2 tirettes</p> <p>Eckmodul mit 2 ausziehbaren Ebenen</p> <p>Módulo angular con 2 estantes extraíbles</p>	<p>Maniglia Handle Poignée Griff Tirador</p>	<p>0,36 57</p>	<p>PPJM (Door on the right)</p>
			<p>0,36 57</p>	<p>PPKM (Door on the left)</p>
			<p>0,36 56,8</p>	<p>PPJP (Door on the right)</p>
		<p>Push-Pull</p>	<p>0,36 56,8</p>	<p>PPKP (Door on the left)</p>
 <p><b>L 600 x P 500 x H 1065 mm</b></p>	<p><b>MODULO per termosigillatrice con anta e predisposizione per autoclave sopra il piano (piano escluso)</b></p> <p>Module for thermosigilator with door and for autoclave arrangement under the surface (surface excluded)</p> <p>Module pour thermoscelleuse avec porte et pré-équipement pour autoclave sur le plan (plan non compris)</p> <p>Modul für Wärmeversiegelung mit Tür und Vorrichtung für Autoklav auf der Ebene (Ebene nicht inkl.)</p> <p>Módulo para termoselladora con hoja y predisposición para autoclave sobre la encimera (encimera no incluida)</p>	<p>Maniglia Handle Poignée Griff Tirador</p>	<p>0,3 38</p>	PTAM
		<p>Push-Pull</p>	<p>0,3 37,6</p>	

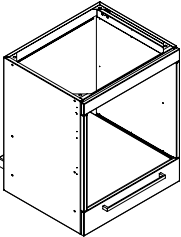
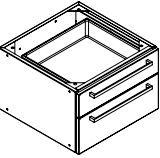
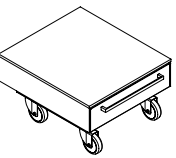
	<b>Descrizione</b> / Description Description / Beschreibung / Descripción	<b>Apertura</b> Opening / Ouverture Öffnung / Apertura	<b>M<sup>3</sup></b> <b>Kg</b>	<b>Articolo</b> Item / Article Artikel / Artículo
 <p><b>L 600 x P 500 x H 718 mm</b></p>	<p><b>MODULO per autoclave</b> Module for autoclave Module pour autoclave Modul für Autoklav Módulo para autoclave</p>	<p><b>Maniglia</b> Handle Poignée Griff Tirador</p>	<p>0,21 ----- 23</p>	<p>PAAM</p>
		<p><b>Senza maniglia</b> Without handle Sans poignée Ohne griff Sin tirador</p>	<p>0,21 ----- 22,8</p>	
 <p><b>L 500 x P 500 x H 328 mm</b></p>	<p><b>MODULO ribassato per autoclave o Multisteril con cassette: 1 B e 1 C</b> Lowered module for autoclave or Multisteril with drawers: 1 B and 1 C Module surbaissé pour autoclave ou multisteril avec tiroirs: 1 B et 1 C Gesenktes Modul für Autoklav oder Multisteril mit Schubladen: 1 B und 1 C Módulo bajo para autoclave o multisteril con cajones: 1 B y 1 C</p> <p><b>Bacinelle / Trays / Intérieurs de tiroir</b> <b>Einsätze / Bandejas:</b> <b>1xLBB1, 1xLBC1</b></p>	<p><b>Maniglia</b> Handle Poignée Griff Tirador</p>	<p>0,8 ----- 18</p>	<p>PABM</p>
		<p><b>Push-Pull</b></p>	<p>0,8 ----- 17,6</p>	
 <p><b>L 510 x P 565 x H 310 mm</b></p>	<p><b>CARRELLO porta autoclave con 1 cassetto B e piano in stratificato</b> Autoclave-holder trolley with 1 B drawer and laminated top Chariot porte autoclave avec 1 tiroir B et un plan en stratifié Wagen für Autoklav mit 1 Schublade B und Ebene aus Verbundmaterial Carro porta autoclave con 1 cajón B y encimera de estratificado</p> <p><b>Bacinelle / Trays / Intérieurs de tiroir</b> <b>Einsätze / Bandejas:</b> <b>1xLBA2</b></p>	<p><b>Maniglia</b> Handle Poignée Griff Tirador</p>	<p>0,1 ----- 26,1</p>	<p>PACM</p>
		<p><b>Push-Pull</b></p>	<p>0,1 ----- 25,9</p>	

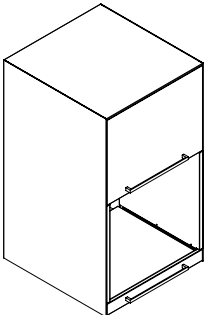
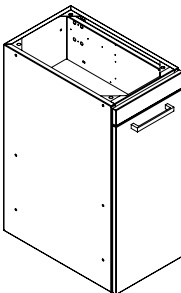
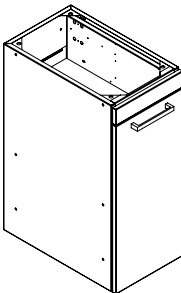
	<b>Descrizione</b> / Description Description / Beschreibung / Descripción	<b>Apertura</b> Opening / Ouverture Öffnung / Apertura	<b>M<sup>3</sup></b> <b>Kg</b>	<b>Articolo</b> Item / Article Artikel / Artículo
	<p><b>COLONNA completa di fianchi e copertura, con anta, 1 ripiano interno e cassetto estraibile per autoclave (da posizionare sopra piano)</b></p> <p>Column complete with sides and cover, with door, 1 inner shelf and removable drawer for autoclave (to be placed over the surface)</p> <p>Colonne avec flancs et couverture, porte, 1 étagère intérieure et tiroir extractible pour autoclave (à installer sur le plan)</p> <p>Säule mit Seitenteilen und Abdeckung, Tür, 1 Inneneinlegeboden und ausziehbare Schublade für Autoklav (wird auf der Ebene platziert)</p> <p>Columna con laterales y cobertura, con hoja, 1 estante interno y cajón extraíble para autoclave (para colocar sobre la encimera)</p>	<p><b>Maniglia</b> Handle Poignée Griff Tirador</p>	0,3	PADM
			40	
<p><b>L 606 x P 640 x H 1068 mm</b></p>		<p><b>Push-Pull</b></p>	0,3	PADP
			39,6	
	<p><b>MODULO con anta e due ripiani interni</b></p> <p>Unit with door and 2 interior shelves</p> <p>Module avec porte et 2 étagères internes</p> <p>Schrank mit Tür und 2 Einlegeböden</p> <p>Módulo con puerta y dos estantes interiores</p>	<p><b>Maniglia</b> Handle Poignée Griff Tirador</p>	0,10	PPDM (L. 300 mm)
			21,5	
<p><b>L 300 x P 500 x H 718 mm</b></p> <p><b>L 400 x P 500 x H 718 mm</b></p>		<p><b>Push-Pull</b></p>	0,14	PPGM (L. 400 mm)
			24	
			0,10	PPDP (L. 300 mm)
			21,4	
		<p><b>Push-Pull</b></p>	0,14	PPGP (L. 400 mm)
			23,9	
	<p><b>MODULO con anta e due ripiani interni, con schiena aperta</b></p> <p>Unit with door and 2 interior shelves, open back</p> <p>Module avec porte et 2 étagères internes, ouvert derrière</p> <p>Schrank mit Tür und 2 Einlegeböden, Rückwand geöffnet</p> <p>Módulo con puerta y dos estantes interiores, con panel trasero abierto</p>	<p><b>Maniglia</b> Handle Poignée Griff Tirador</p>	0,10	PPEM (L. 300 mm)
			21	
<p><b>L 300 x P 500 x H 718 mm</b></p> <p><b>L 400 x P 500 x H 718 mm</b></p>		<p><b>Push-Pull</b></p>	0,14	PPHM (L. 400 mm)
			23,5	
			0,10	PPEP (L. 300 mm)
			20,9	
		<p><b>Push-Pull</b></p>	0,14	PPHP (L. 400 mm)
			23,4	

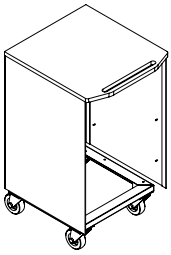
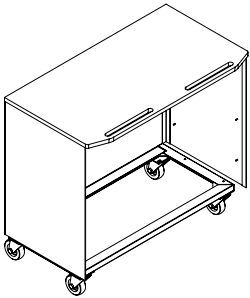
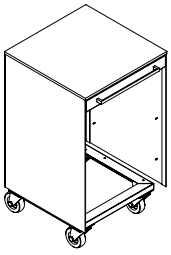
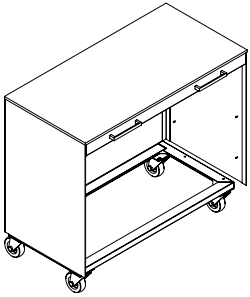
	<b>Descrizione / Description</b> Description / Beschreibung / Descripción	<b>Piano</b> Top / Plan Arbeitsplatte / Encimera	<b>M<sup>3</sup></b> <b>Kg</b>	<b>Articolo</b> Item / Article Artikel / Artículo
 <p><b>L 510 x P 555 x H 900 mm</b></p>	<p><b>Kit ruote + piano sagomato</b> Castor set + shaped top Kit roues + plan façonné Rollenset + geformtem Arbeitsplatte Kit de ruedas + encimera perfilada</p>	Corian®	0,25 ----- 31,5	KRPC
		Stratificato Stratified / Stratifié Schichtstoff Estratificado	0,25 ----- 31	KRPS
		Vetro Glass / Verre Glas / Vidrio	0,25 ----- 36	KRPV
 <p><b>L 1010 x P 555 x H 900 mm</b></p>	<p><b>Kit ruote + piano sagomato L 1010 mm</b> Castor set + shaped top 1010 mm Kit roues + plan façonné 1010 mm Rollenset + geformtem Arbeitsplatte 1010 mm Kit de ruedas + encimera perfilada 1010 mm</p>	Corian®	0,50 ----- 49	KRPC2
		Stratificato Stratified / Stratifié Schichtstoff Estratificado	0,50 ----- 48	KRPS2
		Vetro Glass / Verre Glas / Vidrio	0,50 ----- 58	KRPV2
	<p><b>MAGGIORAZIONI per piano in vetro</b> Additional charge for glass top Supplément de prix pour plan en verre Aufpreis für Glasarbeitsplatte Cargo adicional para encimera de vidrio</p>	<p>Extra-chiaro / Extra clear / Transparent / Transparent / Trasparente</p> <hr/> <p>Satinato / Satin / Dépoli / Satiniert / Satinado</p>		
 <p><b>L 510 x P 555 x H 908 mm</b></p>	<p><b>Kit ruote + piano inox</b> Castor set + shaped top Kit roues + plan façonné Rollenset + geformtem Arbeitsplatte Kit de ruedas + encimera perfilada</p>	Acciaio Inox Steel / Acier Stahl / Acero	0,25 ----- 32	KRPI
 <p><b>L 1010 x P 555 x H 908 mm</b></p>	<p><b>Kit ruote + piano inox L 1010 mm</b> Castor set + shaped top 1010 mm Kit roues + plan façonné 1010 mm Rollenset + geformtem Arbeitsplatte 1010 mm Kit de ruedas + encimera perfilada 1010 mm</p>	Acciaio Inox Steel / Acier Stahl / Acero	0,50 ----- 49	KRPI2

# PURA | Supporti a pavimento

Floor supports / Supports au sol / Bodengestelle / Soportes de pie

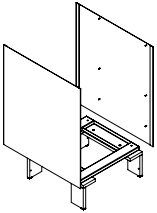
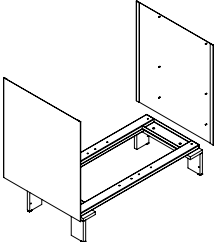
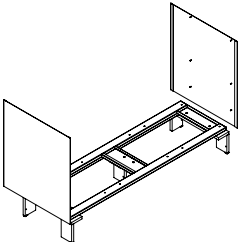
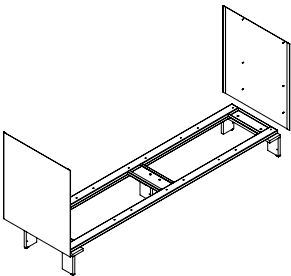
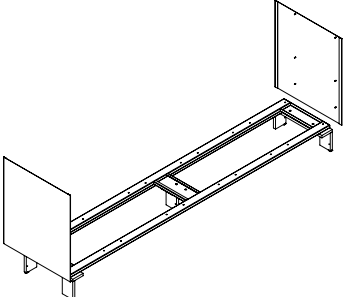
	<b>Descrizione</b> / Description Description / Beschreibung / Descripción	<b>Fianchi</b> Sides / Côtés Seiten / Laterales	<b>M<sup>3</sup></b> <b>Kg</b>	<b>Articolo</b> Item / Article Artikel / Artículo
 <p><b>L 510 mm</b> <b>L 610 mm</b></p>	<p><b>SUPPORTO a pavimento per 1 modulo</b> Floor support for 1 unit Support au sol pour 1 module Bodengestell für 1 Schrank Soporte de pie para 1 módulo</p>	<p><b>Verniciato</b> Painted / Verni Lackiert Pintado</p>	0,30	PS05V (L. 510 mm)
			17	0,36 18
 <p><b>L 1010-1110 mm</b></p>	<p><b>SUPPORTO a pavimento per 2 moduli</b> Floor support for 2 units Support au sol pour 2 modules Bodengestell für 2 Schränke Soporte de pie para 2 módulos</p>	<p><b>Verniciato</b> Painted / Verni Lackiert Pintado</p>	0,59	PS10V (L. 1010 mm)
			22	0,65 23
 <p><b>L 1510-1610 mm</b></p>	<p><b>SUPPORTO a pavimento per 3 moduli</b> Floor support for 3 units Support au sol pour 3 modules Bodengestell für 3 Schränke Soporte de pie para 3 módulos</p>	<p><b>Verniciato</b> Painted / Verni Lackiert Pintado</p>	0,89	PS15V (L. 1510 mm)
			26	0,95 27
 <p><b>L 2010-2110 mm</b></p>	<p><b>SUPPORTO a pavimento per 4 moduli</b> Floor support for 4 units Support au sol pour 4 modules Bodengestell für 4 Schränke Soporte de pie para 4 módulos</p>	<p><b>Verniciato</b> Painted / Verni Lackiert Pintado</p>	1,18	PS20V (L. 2010 mm)
			31	1,24 32
 <p><b>L 2510-2610 mm</b></p>	<p><b>SUPPORTO a pavimento per 5 moduli</b> Floor support for 5 units Support au sol pour 5 modules Bodengestell für 5 Schränke Soporte de pie para 5 módulos</p>	<p><b>Verniciato</b> Painted / Verni Lackiert Pintado</p>	1,48	PS25V (L. 2510 mm)
			36	1,54 37



# PURA | Basamenti

Base units / Bases / Sockel / Bases

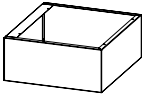
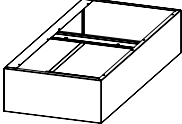
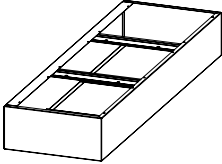
	<b>Descrizione / Description</b> Description / Beschreibung / Descripción	<b>M<sup>3</sup></b> <b>Kg</b>	<b>Articolo</b> Item / Article Artikel / Artículo
	<b>L 500 x P 445 x H 200 mm</b> Basamento / Base unit / Base Sockel / Base: <b>L 500</b>	0,04 3,5	PB05
	<b>L 600 x P 445 x H 200 mm</b> Basamento / Base unit / Base Sockel / Base: <b>L 600</b>	0,05 4	PB06
	<b>L 1000 x P 445 x H 200 mm</b> Basamento / Base unit / Base Sockel / Base: <b>L 1000</b>	0,09 6,5	PB10
	<b>L 1100 x P 445 x H 200 mm</b> Basamento / Base unit / Base Sockel / Base: <b>L 1100</b>	0,09 7	PB11
	<b>L 1500 x P 445 x H 200 mm</b> Basamento / Base unit / Base Sockel / Base: <b>L 1500</b>	0,13 12	PB15
<b>L 1600 x P 445 x H 200 mm</b> Basamento / Base unit / Base Sockel / Base: <b>L 1600</b>	0,14 12,5	PB16	

# PURA | Fianchi Sides / Côtés / Seiten / Laterales

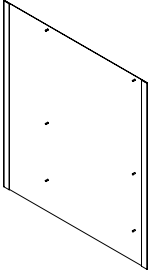
	<b>Descrizione / Description</b> Description / Beschreibung / Descripción	<b>M<sup>3</sup></b> <b>Kg</b>	<b>Articolo</b> Item / Article Artikel / Artículo
	<b>P 640 x H 718 mm</b> <b>Fianco laterale</b> Lateral side / Panneau latéral Seitenwand / Panel lateral	- 6,3	PFA64
	<b>P 700 x H 718 mm</b> <b>Fianco laterale</b> Lateral side / Panneau latéral Seitenwand / Panel lateral	- 6,9	PFA70
	<b>P 640 x H 1065 mm</b> <b>Fianco laterale</b> Lateral side / Panneau latéral Seitenwand / Panel lateral	- 9,0	PFB64
	<b>P 700 x H 1065 mm</b> <b>Fianco laterale</b> Lateral side / Panneau latéral Seitenwand / Panel lateral	- 9,8	PFB70
	<b>P 640 x H 328 mm</b> <b>Fianco laterale</b> Lateral side / Panneau latéral Seitenwand / Panel lateral	- 2,9	PFC64
	<b>P 700 x H 328 mm</b> <b>Fianco laterale</b> Lateral side / Panneau latéral Seitenwand / Panel lateral	- 3,1	PFC70

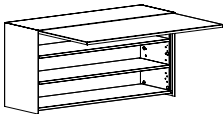
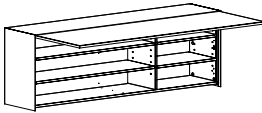
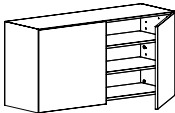
	<b>Descrizione</b> / Description Description / Beschreibung / Descripción	<b>Fianchi</b> Sides / Côtés Seiten / Laterales	<b>M<sup>3</sup></b> <b>Kg</b>	<b>Articolo</b> Item / Article Artikel/Artículo
 <p><b>PENSILE L 1006 mm con anta a ribalta verniciata o in vetro, con 2 ripiani interni</b></p> <p>Wall unit L 1006 mm with flap painted or glass door, with 2 inner shelves</p> <p>Élément haut L 1006 mm avec porte battante peinte ou en verre, avec 2 étagères intérieures</p> <p>Hängeschrank L 1006 mm mit lackierter Kipptür oder Glastür und 2 Inneneinlegeböden</p> <p>Mueble colgante L 1006 mm con hoja basculante pintada o de vidrio, con 2 estantes internos</p> <p><b>L 1006 x P 350 x H 500 mm</b></p>		<p><b>Anta verniciata</b> Painted / Verni Lackiert Pintado</p>	<p>0,16 ----- 34,5</p>	PVOA
		<p><b>Anta in vetro</b> Glass / Verre Glas / Vidrio</p>	<p>0,16 ----- 34,5</p>	PVOAV
 <p><b>PENSILE L 1506 mm con anta a ribalta verniciata o in vetro, con 2+2 ripiani interni e divisorio verticale</b></p> <p>Wall unit L 1506 mm with flap painted or glass door, with 2+2 inner shelves and vertical partition</p> <p>Élément haut L 1506 mm avec porte battante peinte ou en verre, avec 2+2 étagères intérieures et séparation verticale</p> <p>Hängeschrank L 1506 mm mit lackierter Kipptür oder Glastür, 2+2 Inneneinlegeböden und senkrechtem Trennelement</p> <p>Mueble colgante L 1506 mm con hoja basculante pintada o de vidrio, con 2+2 estantes internos y separador vertical</p> <p><b>L 1506 x P 350 x H 500 mm</b></p>		<p><b>Anta verniciata</b> Painted / Verni Lackiert Pintado</p>	<p>0,25 ----- 63,5</p>	PVOB
		<p><b>Anta in vetro</b> Glass / Verre Glas / Vidrio</p>	<p>0,25 ----- 63,5</p>	PVOBV
 <p><b>PENSILE L 1006 mm con 2 ante battenti e 2 ripiani interni</b></p> <p>Cupboard L 1006 mm with 2 doors and 2 internal shelves</p> <p>Élément mural L 1006 mm avec 2 portes battantes et 2 étagères intérieures</p> <p>Hängeschrank L 1006 mm mit 2 Türflügeln und 2 Inneneinlegeböden</p> <p>Mueble colgante L 1006 mm con 2 hojas batientes y 2 estantes interiores</p> <p><b>L 1006 x P 350 x H 500 mm</b></p>		<p><b>Verniciato</b> Painted / Verni Lackiert Pintado</p>	<p>0,25 ----- 62,5</p>	PVOC

	<b>Descrizione / Description</b> Description / Beschreibung / Descripción	<b>Fianchi</b> Sides / Côtés Seiten / Laterales	<b>M<sup>3</sup></b> <b>Kg</b>	<b>Articolo</b> Item / Article Artikel/Artículo
	<b>LAMPADA A LED sottopensile/ sottomensola con interruttore touch</b> Under-floor/-shelf LED lamp with touch switch Lampe à LED sous élément haut/sous étagère avec interrupteur tactile LED-lampe für Unterbau Hängeschrank/Regal mit Touch-Schalter Lámpara de LED debajo del mueble colgante/estante con interruptor táctil	<i>Fino a / Up to</i> L = 1000 mm		PLEDE10
		L = da / from 1000 a / to 1500 mm		PLEDE15
	<b>LAMPADA A LED interna al pensile</b> LED lamp inside the wall unit Lampe à LED à l'intérieur de l'élément haut LED-lampe Hängeschrankinnenseite Lámpara de LED incorporada dentro del mueble colgante	<i>Fino a / Up to</i> L = 1000 mm		PLEDI10
		L = da / from 1000 a / to 1500 mm		PLEDI15
	<b>Portarotolo interno al pensile</b> Roll holder inside the cupboard Porte-rouleau intérieur pour élément mural Rollenhalterung für Hängeschrankinnenseite Porta-rollos dentro del mueble colgante		- ----- 2,3	PAP01
<b>L 330 x P 210 x H 200 mm</b>				
	<b>Porta Tray interno al pensile</b> Tray holder inside the cupboard Porte Tray intérieur pour élément mural Trayhalterung für Hängeschrankinnenseite Porta-Tray dentro del mueble colgante		- ----- 6,7	PAP02
		<b>L 200 x P 290 x H 430 mm</b>		
	<b>Porta Tubs interno al pensile</b> Tubs holder inside the cupboard Porte Tubs intérieur pour élément mural Tubshalterung für Hängeschrankinnenseite Porta-Tubs dentro del mueble colgante		- ----- 7	PAP03
		<b>L 360 x P 290 x H 430 mm</b>		
	<b>Coppia di prese di corrente schuko sotto al pensile</b> Pair of Schuko power outlets under the wall unit Deux prises de courant Schuko sous l'élément haut 1 Paar Schuko-Stromsteckdosen unter Hängeschrank Par de tomas de corriente schuko debajo del mueble colgante			PAP04

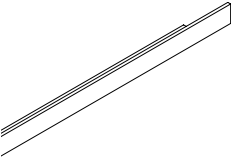
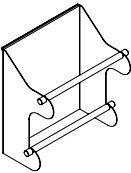
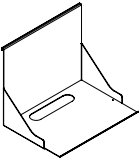
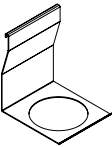
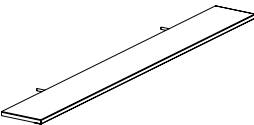
	<b>Descrizione / Description</b> Description / Beschreibung / Descripción	<b>M<sup>3</sup></b> <b>Kg</b>	<b>Articolo</b> Item / Article Artikel / Artículo
	<p><b>Barra attrezzata in acciaio inox: al metro lineare</b></p> <p>Equipped bar in stainless steel: per meter Barre équipée en acier inox: au mètre Edelstahl - Stangenausstattung: meterweise Barra equipada de acero inoxidable: por metro</p>	3 Kg/m	PA01
<b>SP 15 x H 50 mm</b>			
	<p><b>Portarotolo da esterno in acciaio inox</b></p> <p>Roll holder for exterior in stainless steel Porte-rouleau extérieur en acier inox Edelstahl-Rollenhalterung für außen Porta-rollos para exterior de acero inoxidable</p>	- ----- 4,5	PA02
<b>L 386 mm x P 250 x H 400 mm</b>			
	<p><b>Supporto per attrezzature in acciaio inox</b></p> <p>Support for equipments in stainless steel Support pour équipements en acier inox Edelstahl-Halterung für Geräte Soporte para equipos de acero inoxidable</p>	- ----- 3,7	PA03
<b>L 350 mm x P 270 x H 300 mm</b>			
	<p><b>Supporto per contenitore aghi in acciaio inox (foro ø 130 mm)</b></p> <p>Support for needle container in stainless steel (hole ø 130 mm) Support pour conteneur à aiguilles en acier inox (trou ø 130 mm) Halterung für Nadelbehälter aus Edelstahl (Bohrung ø 130 mm) Soporte para contenedor agujas de acero inoxidable (orificio ø 130 mm)</p>	- ----- 0,9	PA04
<b>L 160 mm x P 170 x H 210 mm</b>			
	<p><b>Mensola completa di kit di fissaggio: al metro lineare</b></p> <p>Shelf with mounting kit: per meter Étagère fournie avec kit de fixation: au mètre Regal mit Befestigungsset: meterweise Repisa con kit de fijación: por metro</p>	3,5 Kg/m	PME
<b>P 180 mm</b>			

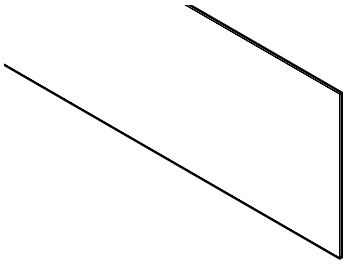
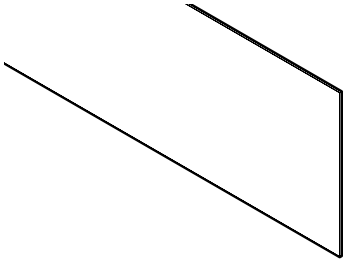
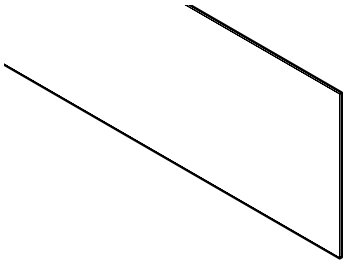
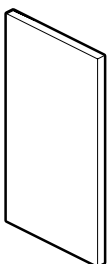
	Descrizione / Description Description / Beschreibung / Descripción	M <sup>3</sup> Kg	Articolo Item / Article Artikel / Artículo
 <p><b>Tamponamento di chiusura tra piano e pensile in acciaio inox: al metro lineare</b> Closing element between top and shelf in stainless steel: per meter Cache de fermeture entre le plan et l'élément mural en acier inox: au mètre Schließabdichtung zwischen Ebene und Hängeschrank aus Edelstahl: meterweise Elemento de relleno entre encimera y mueble colgante de acero inoxidable: por metro</p> <p>P 20 x H 576 mm</p>	- 9	PTCI	
 <p><b>Tamponamento di chiusura tra piano e pensile in stratificato: al metro lineare</b> Closing element between top and shelf in stratified laminate: per meter Cache de fermeture entre le plan et l'élément mural en stratifié: au mètre Schließabdichtung zwischen Ebene und Hängeschrank aus Verbundmaterial: meterweise Elemento de relleno entre encimera y mueble colgante de estratificado: por metro</p> <p>P 12 x H 584 mm</p>	- 11,1	PTCS	
 <p><b>Tamponamento di chiusura tra piano e pensile in Corian®: al metro lineare</b> Closing element between top and shelf in Corian®: per meter Cache de fermeture entre le plan et l'élément mural en Corian®: au mètre Schließabdichtung zwischen Ebene und Hängeschrank aus Corian®: meterweise Elemento de relleno entre encimera y mueble colgante de Corian®: por metro</p> <p>P 12 x H 584 mm</p>	- 12,7	PTCC	
 <p><b>Pannello laterale verniciato di sostegno piano</b> Painted side panel supporting the top Panneau latéral peint de soutien du plan Lackiertes Seitenpaneel zum Abstützen der Ebene Panel lateral pintado para soporte encimera</p> <p>L 25 x P 640 x H 918 mm</p>	- 14	PSLS	

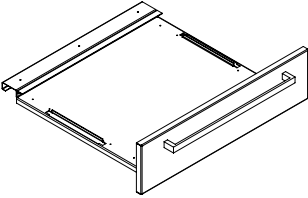
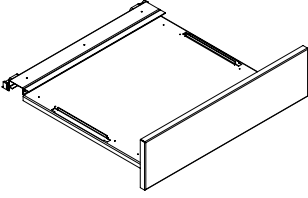
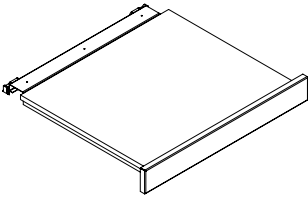
	<b>Descrizione / Description</b> Description / Beschreibung / Descripción		<b>M<sup>3</sup></b> <b>Kg</b>	<b>Articolo</b> Item / Article Artikel / Artículo
	<b>CASSETTO con maniglia</b> Drawer with handle Tiroir avec poignée Schublade mit Griff Cajón con tirador	A) H 65	- 4,2	PCAAM
		B) H 130	- 5,2	PCABM
		C) H 195	- 5,8	PCACM
		D) H 260	- 6,8	PCADM
	<b>CASSETTO Push-Pull</b> Drawer Push-Pull Tiroir Push-Pull Schublade Push-Pull Cajón Push-Pull	A) H 65	- 4	PCAAP
		B) H 130	- 5	PCABP
		C) H 195	- 5,8	PCACP
		D) H 260	- 6,6	PCADP
	<b>CASSETTO estraibile con ripiano in Corian® o stratificato</b> Pull-out drawer with top in Corian® or stratified laminate Tiroir extractible avec tablette en Corian® ou stratifié Ausziehbarer Schublade mit Einlegeboden aus Corian® oder Verbundmaterial Cajón extraíble con estante de Corian® o estratificado	<b>Stratificato</b> Stratifié / Stratifié Schichtstoff Estratificado	- 8,8	PCAAES (L 500 mm)
		<b>Corian®</b>	- 9,3	PCAAEC (L 500 mm)
		<b>Stratificato</b> Stratifié / Stratifié Schichtstoff Estratificado	- 9,3	PCAAES6 (L 600 mm)
		<b>Corian®</b>	- 9,8	PCAAEC6 (L 600 mm)

L 500  
L 600

PCAAPK

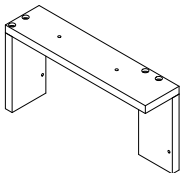
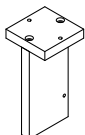
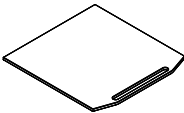
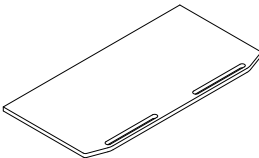
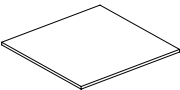
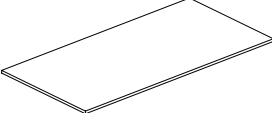
	<b>Descrizione</b> / Description Description / Beschreibung / Descripción		<b>M<sup>3</sup></b> <b>Kg</b>	<b>Articolo</b> Item / Article Artikel / Artículo	
	<b>PIEDE in alluminio</b> Aluminium foot Pied en aluminium Aluminiumfuß Pata de aluminio	<b>DX / RH</b> Droite / Rechts Dcho	- 4	PPAD	
		<b>SX / LH</b> Gauche / Links Izq	- 4	PPAS	
	<b>PIEDE CENTRALE in alluminio</b> Aluminium foot Pied en aluminium Aluminiumfuß Pata de aluminio		- 1,5	PPAC	
	<b>PIANO sagomato per servomobile</b> Shaped top for movable unit Plan façonné pour module mobile Geformte Arbeitsplatte für Rollenschrank Encimera perfilada para módulo móvil	<b>Corian®</b>	- 5,7	PPSC	
		<b>Stratificato</b> Stratified / Stratifié Schichtstoff Estratificado	- 5	PPSS	
		<b>Vetro / Glass</b> Verre / Glas / Vidrio	- 10	PPSV	
		<b>Extra-chiaro / Extra clear / Transparent / Transparent / Extra-claro</b>  <b>Satinato / Satin / Dépoli / Satiniert Satinado</b>			
	<b>PIANO sagomato per servomobile</b> Shaped top for movable unit Plan façonné pour module mobile Geformte Arbeitsplatte für Rollenschrank Encimera perfilada para módulo móvil	<b>Corian®</b>	- 11,5	PPSC2	
		<b>Stratificato</b> Stratified / Stratifié Schichtstoff Estratificado	- 10	PPSS2	
		<b>Vetro / Glass</b> Verre / Glas / Vidrio	- 20	PPSV2	
		<b>Extra-chiaro / Extra clear / Transparent / Transparent / Extra-claro</b>  <b>Satinato / Satin / Dépoli / Satiniert Satinado</b>			
	<b>PIANO inox L 510 mm per servomobile spessore 20 mm</b> Top for movable unit, 20 mm thick Plan pour module mobile, ép. 20 mm Arbeitsplatte für Rollenschrank, St. 20 mm Encimera para módulo móvil, de 20 mm de esp.		- 6	PPSI	
	<b>PIANO inox L 1010 mm per servomobile spessore 20 mm</b> Top for movable unit, 20 mm thick Plan pour module mobile, ép. 20 mm Arbeitsplatte für Rollenschrank, St. 20 mm Encimera para módulo móvil, de 20 mm de esp.		- 12	PPSI2	

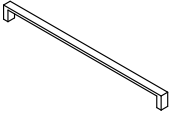
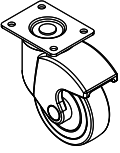
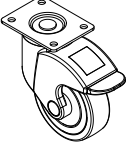
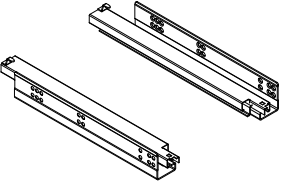
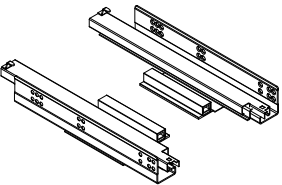
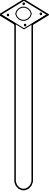
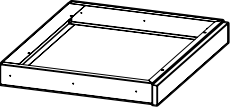
	<b>Descrizione / Description</b> Description / Beschreibung / Descripción	<b>M<sup>3</sup></b> <b>Kg</b>	<b>Articolo</b> Item / Article Artikel / Artículo
	<b>MANIGLIA in alluminio per "Look"/"Pura"</b> Aluminium handle for "Look"/"Pura" Poignée en aluminium pour "Look"/"Pura" Griff aus Aluminium für "Look"/"Pura" Tirador de aluminio para "Look"/"Pura"	- 0,4	MA020
	<b>RUOTA senza freno</b> Castor without brake Roue sans frein Rad ohne Bremse Rueda sin freno	- 0,6	RUO26
	<b>RUOTA con freno</b> Castor with brake Roue avec frein Rad mit Bremse Rueda con freno	- 0,7	RUO27
	<b>COPPIA DI GUIDE con rientro ammortizzato</b> Pair of guides with soft closing Couple de glissières avec amortisseur Eine Paar Führungen mit Softeinzug Par de guías con cierre suave	- 1	GUI66
	<b>COPPIA DI GUIDE per cassetto Push-Pull</b> Pair of guides for Push-Pull drawer Couple de glissières pour tiroir Push-Pull Eine Paar Führungen für Push-Pull Schublade Par de guías para cajón Push-Pull	- 1	GUI67
 <p data-bbox="130 1742 284 1769"><b>H 918 mm - Ø 60</b></p>	<b>Supporto in tubolare per piano</b> Tube top bracket Support en tube pour plan Rundrohrbeine für Arbeitsplatte Soporte en tubular para la encimera	- 8	PSTP
 <p data-bbox="130 2078 341 2105"><b>L 600 x P 500 x H 65 mm</b></p>	<b>Cornice di finitura H 65 mm per vano L 600 mm completa di frontale</b> Finishing frame h 65 mm for compartment l 600 mm with front Cadre de finition h 65 mm pour compartiment l 600 mm avec façade Zierrahmen H 65 mm für Fach L 600 mm mit Front Marco de acabado h 65 mm para compartimento l 600 mm con frente	- 3	PCRA



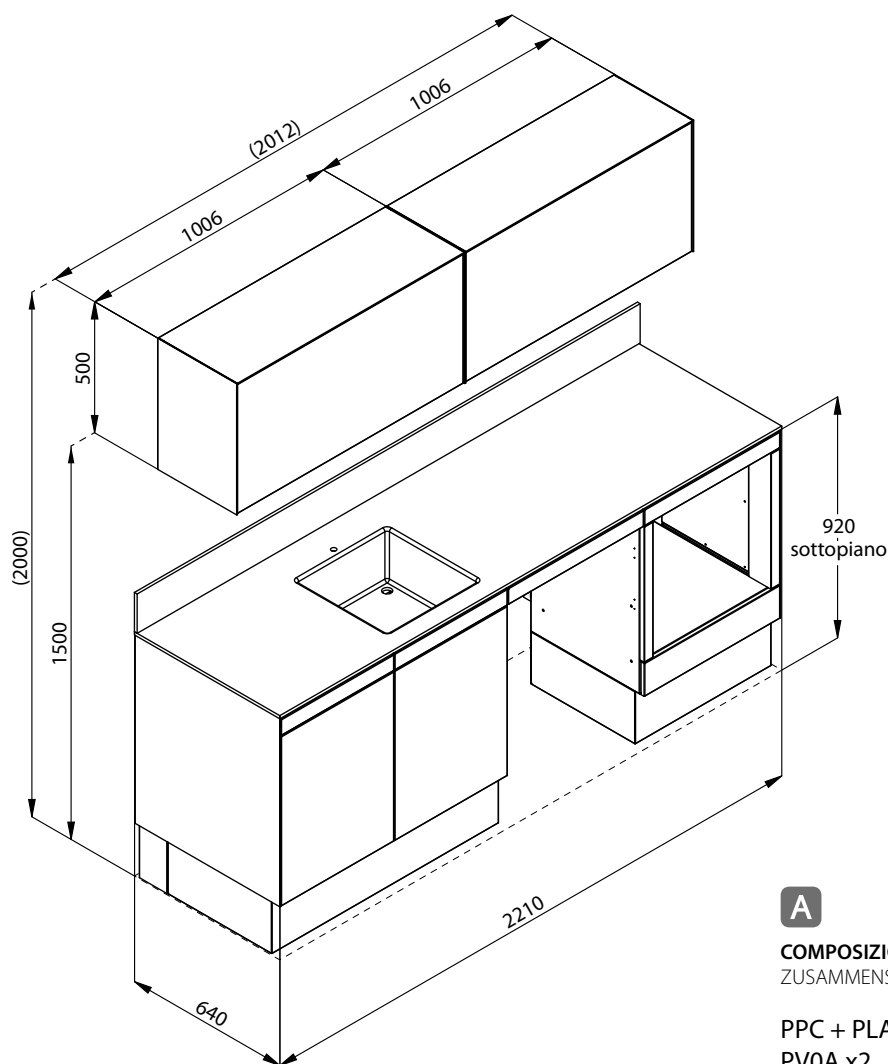

**A**

**COMPOSIZIONE / COMPOSITION / COMPOSITION  
ZUSAMMENSTELLUNG / COMPOSICIÓN**

PPC + PLA + PCRA + PAA  
PV0A x2

**La composizione è comprensiva di bacinelle standard.  
Rubinetto escluso.**

Trays included. Mixer excluded  
Intérieurs de tiroirs inclus. Robinet pas compris.  
Standard Schubladeneinsätze sind enthalten. Armatur ist ausgeschlossen.  
La composición incluye bandejas estándar.  
Grifo excluido.

	Con piedi / On feet Sur pieds / Mit Füßen / Con patas		Basamento / Base units / Bases / Sockel / Bases	
	Maniglia Handle / Poignée Griff / Tirador	Push-Pull	Maniglia Handle / Poignée Griff / Tirador	Push-Pull
1 <b>Piano in laminato Fenix® + Alzatina</b> "Fenix®" - laminate worktop / Plan de travail en laminé "Fenix®" / Arbeitsplatte aus Laminat "Fenix®" / Encimera de laminado "Fenix®"	+V2S			
2 <b>Piano in stratificato + Alzatina</b> Stratified top / Plan stratifié / Arbeitsplatte aus Schichtstoff / Encimera de estratificado	+V2S			
3 <b>Piano in acciaio inox + Alzatina</b> Steel top / Plan en acier Arbeitsplatte aus stahl / Encimera de acero	+V11 +VAA			
4 <b>Piano in Corian® + Alzatina</b> Corian® top / Plan en Corian® Arbeitsplatte aus Corian® / Encimera de Corian®	+VPC			

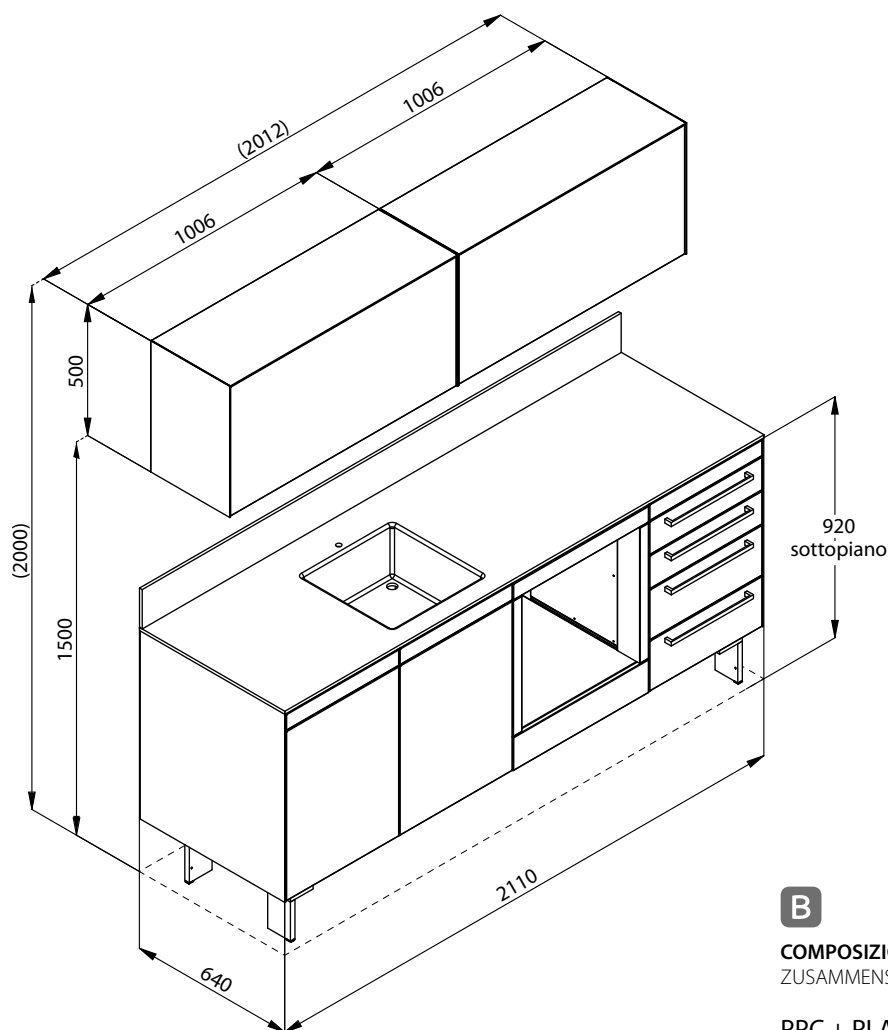

**B**

**COMPOSIZIONE / COMPOSITION / COMPOSITION  
ZUSAMMENSTELLUNG / COMPOSICIÓN**

PPC + PLA + PAA + P4B  
PV0A x2

**La composizione è comprensiva di bacinelle standard.  
Rubinetto escluso.**

Trays included. Mixer excluded

Intérieurs de tiroirs inclus. Robinet pas compris.

Standard Schubladeneinsätze sind enthalten. Armatur ist ausgeschlossen.

La composición incluye bandejas estándar.

Grifo excluido.

	Con piedi / On feet Sur pieds / Mit Füßen / Con patas		Basamento / Base units / Bases / Sockel / Bases	
	Maniglia Handle / Poignée Griff / Tirador	Push-Pull	Maniglia Handle / Poignée Griff / Tirador	Push-Pull
1 <b>Piano in laminato Fenix® + Alzatina</b> "Fenix®" - laminate worktop / Plan de travail en laminé "Fenix®" / Arbeitsplatte aus Laminat "Fenix®" / Encimera de laminado "Fenix®"	+ V2S			
2 <b>Piano in stratificato + Alzatina</b> Stratified top / Plan stratifié / Arbeitsplatte aus Schichtstoff / Encimera de estratificado	+ V2S			
3 <b>Piano in acciaio inox + Alzatina</b> Steel top / Plan en acier Arbeitsplatte aus stahl / Encimera de acero	+ V11 +VAA			
4 <b>Piano in Corian® + Alzatina</b> Corian® top / Plan en Corian® Arbeitsplatte aus Corian® / Encimera de Corian®	+ VPC			

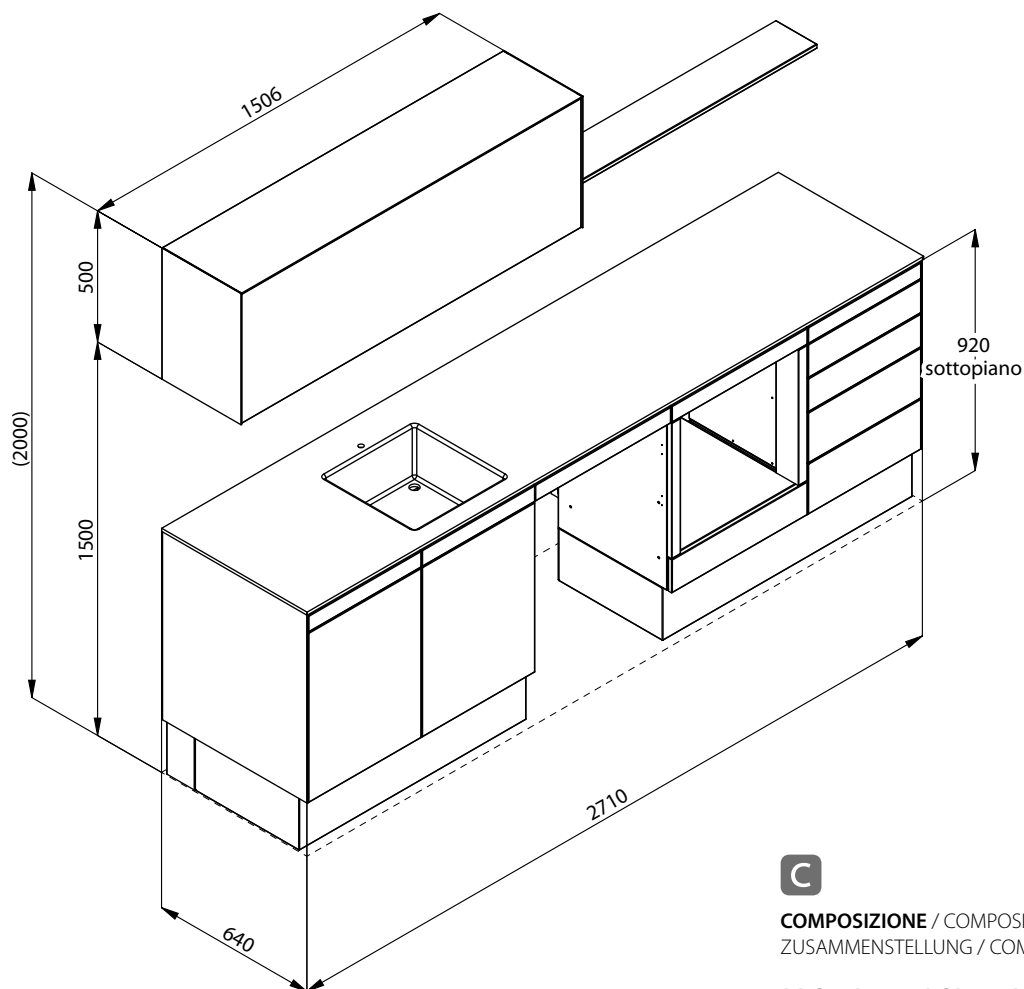

**COMPOSIZIONE** / COMPOSITION / COMPOSITION  
ZUSAMMENSTELLUNG / COMPOSICIÓN

PPC + PLA + PCRA + PAA + P4B  
PV0B + PME (L 1200 mm)

**La composizione è comprensiva di bacinelle standard. Rubinetto escluso.**

Trays included. Mixer excluded  
Intérieurs de tiroirs inclus. Robinet pas compris.  
Standard Schubladeneinsätze sind enthalten. Armatur ist ausgeschlossen.  
La composición incluye bandejas estándar.  
Grifo excluido.

	Con piedi / On feet Sur pieds / Mit Füßen / Con patas		Basamento / Base units / Bases / Sockel / Bases	
	Maniglia Handle / Poignée Griff / Tirador	Push-Pull	Maniglia Handle / Poignée Griff / Tirador	Push-Pull
1 <b>Piano in laminato Fenix®</b> "Fenix®" - laminate worktop / Plan de travail en laminé "Fenix®" / Arbeitsplatte aus Laminat "Fenix®" / Encimera de laminado "Fenix®"	+ V2S			
2 <b>Piano in stratificato</b> Stratified top / Plan stratifié / Arbeitsplatte aus Schichtstoff / Encimera de estratificado	+ V2S			
3 <b>Piano in acciaio inox</b> Steel top / Plan en acier Arbeitsplatte aus stahl / Encimera de acero	+ V11 + VAA			
4 <b>Piano in Corian®</b> Corian® top / Plan en Corian® Arbeitsplatte aus Corian® / Encimera de Corian®	+ VPC			

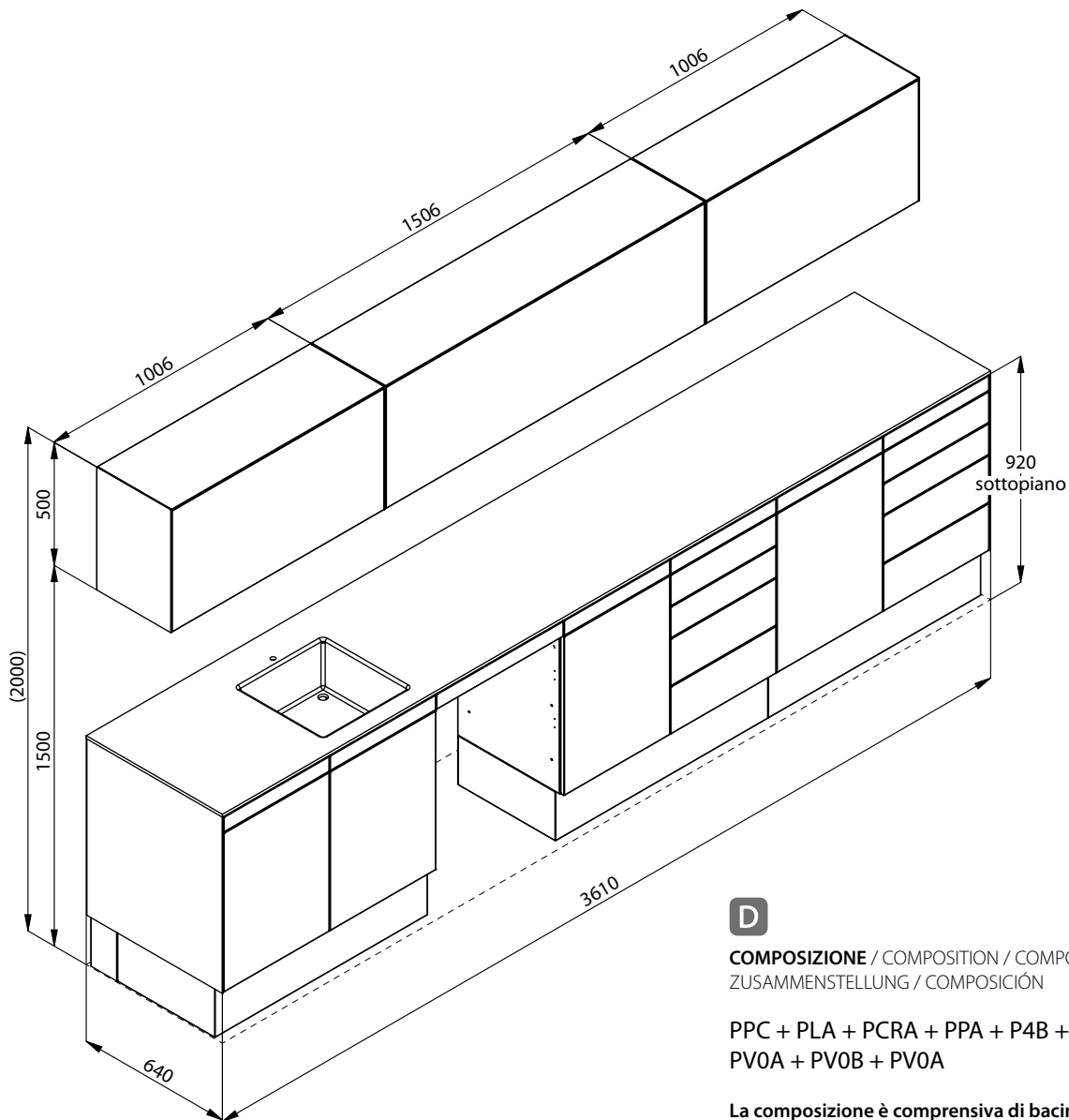

**D**

**COMPOSIZIONE / COMPOSITION / COMPOSITION  
ZUSAMMENSTELLUNG / COMPOSICIÓN**

**PPC + PLA + PCRA + PPA + P4B + PPA + P4B  
PVOA + PVOB + PVOA**

**La composizione è comprensiva di bacinelle standard.  
Rubinetto escluso.**

Trays included. Mixer excluded  
Intérieurs de tiroirs inclus. Robinet pas compris.  
Standard Schubladeneinsätze sind enthalten. Armatur ist ausgeschlossen.  
La composición incluye bandejas estándar.  
Grifo excluido.

	Con piedi / On feet Sur pieds / Mit Füßen / Con patas		Basamento / Base units / Bases / Sockel / Bases	
	Maniglia Handle / Poignée Griff / Tirador	Push-Pull	Maniglia Handle / Poignée Griff / Tirador	Push-Pull
1 <b>Piano in laminato Fenix®</b> "Fenix®" - laminate worktop / Plan de travail en laminé "Fenix®" Arbeitsplatte aus Laminat "Fenix®" / Encimera de laminado "Fenix®"	+ V2S			
2 <b>Piano in stratificato</b> Stratified top / Plan stratifié / Arbeitsplatte aus Schichtstoff / Encimera de estratificado	+ V2S			
3 <b>Piano in acciaio inox</b> Steel top / Plan en acier Arbeitsplatte aus stahl / Encimera de acero	+ V11 + VAA			
4 <b>Piano in Corian®</b> Corian® top / Plan en Corian® Arbeitsplatte aus Corian® / Encimera de Corian®	+ VPC			

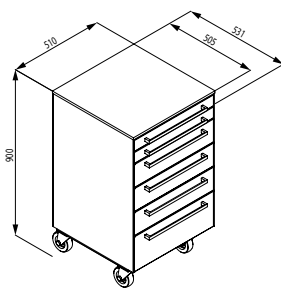
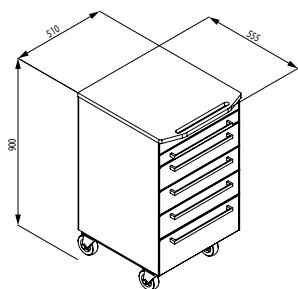

## E

**SERVOMOBILE** / COMPOSITION / COMPOSITION  
ZUSAMMENSTELLUNG / COMPOSICIÓN

**P5A + KRP**

**Il servomobile è comprensivo di bacinelle standard.**

Trays included.  
Intérieurs de tiroirs inclus.  
Standard Schubladeneinsätze sind enthalten.  
La composición incluye bandejas estándar.

	<b>Maniglia</b> Handle / Poignée Griff / Tirador	<b>Push-Pull</b>
<b>1 Piano in stratificato</b> Stratified top / Plan stratifié / Arbeitsplatte aus Schichtstoff / Encimera de estratificado		
<b>2 Piano in vetro</b> Glass top / Plan en verre Arbeitsplatte aus Glas / Encimera de vidrio		
<b>3 Piano in Corian®</b> Corian® top / Plan en Corian® Arbeitsplatte aus Corian® / Encimera de Corian®		
<b>4 Piano in acciaio inox</b> Steel top / Plan en acier Arbeitsplatte aus stahl / Encimera de acero		

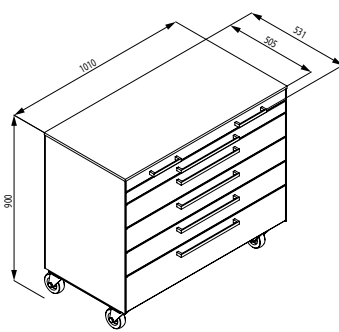
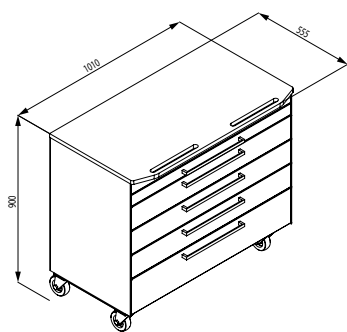

## F

**SERVOMOBILE** / COMPOSITION / COMPOSITION  
ZUSAMMENSTELLUNG / COMPOSICIÓN

**PSA\_2 + KRP\_2**

**Il servomobile è comprensivo di bacinelle standard.**

Trays included.  
Intérieurs de tiroirs inclus.  
Standard Schubladeneinsätze sind enthalten.  
La composición incluye bandejas estándar.

	<b>Maniglia</b> Handle / Poignée Griff / Tirador	<b>Push-Pull</b>
<b>1 Piano in stratificato</b> Stratified top / Plan stratifié / Arbeitsplatte aus Schichtstoff / Encimera de estratificado		
<b>2 Piano in vetro</b> Glass top / Plan en verre Arbeitsplatte aus Glas / Encimera de vidrio		
<b>3 Piano in Corian®</b> Corian® top / Plan en Corian® Arbeitsplatte aus Corian® / Encimera de Corian®		
<b>4 Piano in acciaio inox</b> Steel top / Plan en acier Arbeitsplatte aus stahl / Encimera de acero		

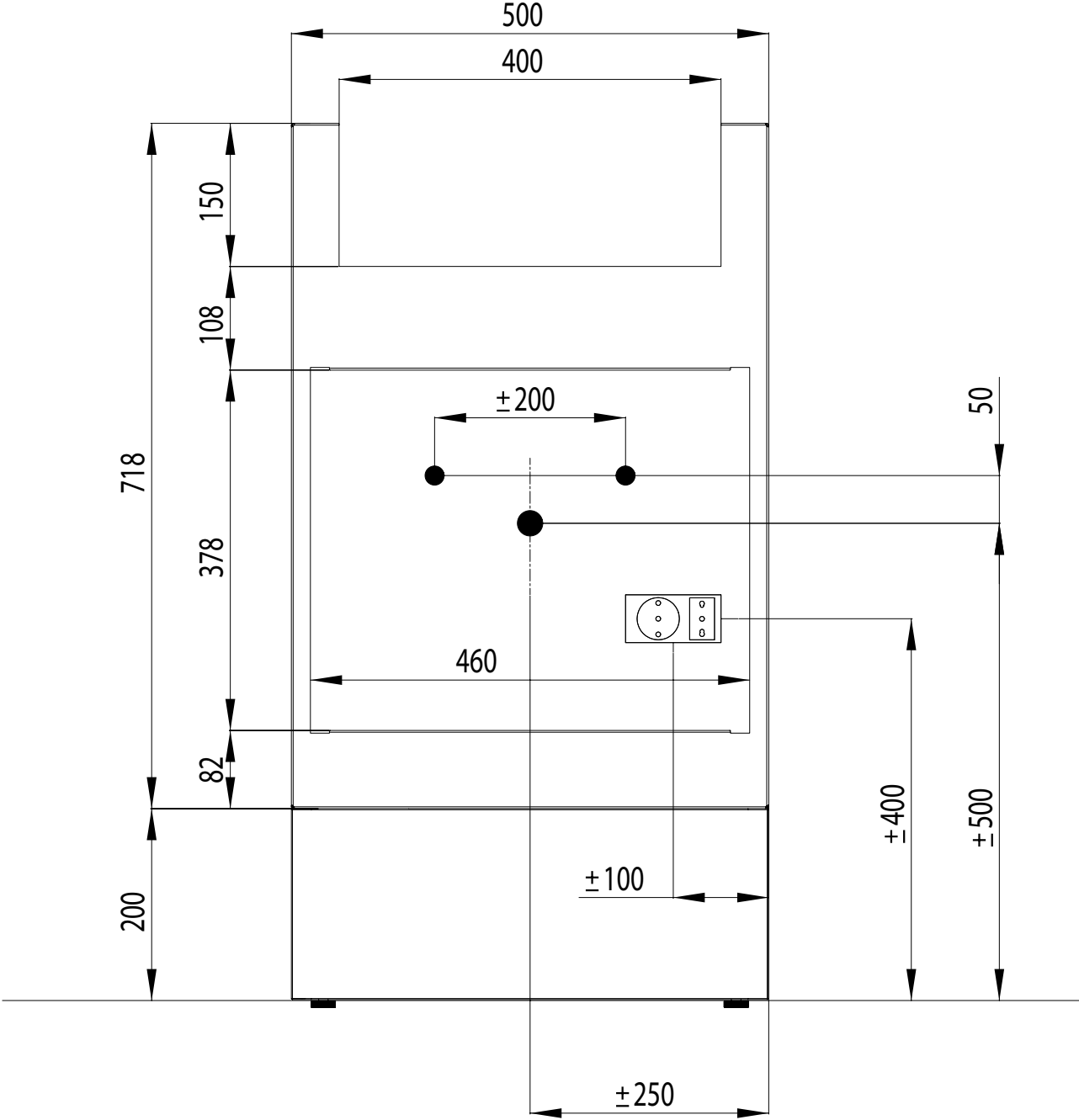

# CONDIZIONI GENERALI DI VENDITA

General terms of sale / Conditions generales de vente

Allgemeine Verkaufsbedingungen / Condiciones generales de venta



Il presente listino sostituisce e annulla tutti i precedenti e può essere modificato in qualsiasi momento senza preavviso. I prezzi si intendono al netto di iva. **L'imballo non è compreso nel prezzo.** L'installazione è a carico del cliente.

L'ordine, e ogni modifica ad esso, dovrà essere inoltrato per iscritto e sarà da considerarsi accettato solo dopo l'invio di una conferma da parte di Loran srl. I termini fissati per la spedizione non sono tassativi e in nessun caso potranno costituire pretesto per ritardi di pagamento o richiesta di risarcimento.

**La merce viaggia a rischio e pericolo del committente, franco stabilimento Loran srl a Pieve di Soligo.** Se non indicato per iscritto, la merce sarà spedita col mezzo ritenuto più opportuno da Loran srl. **Eventuali reclami di trasporto devono essere fatti al momento della consegna direttamente al vettore.**

Eventuali difetti di fabbricazione devono essere comunicati a mezzo raccomandata alla sede Loran srl di Pieve di Soligo entro 8 giorni dalla data di ricevimento merce, anche se segnalati prima in altra forma. In ogni caso non danno diritto al cliente di sospendere i pagamenti.

Nessun materiale dovrà essere reso senza nostra autorizzazione scritta. I resi autorizzati ci dovranno pervenire in porto franco accompagnati da documento di trasporto che indichi il numero e la data della fattura relativa alla fornitura originaria e saranno gravati del 15% per spese generali.

Il materiale di produzione Loran srl ha garanzia di anni due, salvo eventuali danni o manomissioni causati dall'utilizzatore.

La merce venduta rimane di proprietà della venditrice fino al pagamento totale da parte dell'acquirente. In caso contrario la venditrice si riserva la facoltà di ritirarla in qualsiasi momento. Ogni controversia sarà competenza del foro di Treviso (Italia)

This price list can be modified at any time, without notice. The prices do not include vat. **Packing is not included in the price.** Installation shall be charged to the customer.

Order as well as any modifications of such orders shall be made in writing and shall be considered accepted upon our written confirmation. Delivery terms are not binding and under no circumstance may they be used as a pretext to justify delays in payment or claims for compensation.

**The goods travel at the purchaser's risk on a ex-works basis from our factory in Pieve di Soligo (Italy):** unless otherwise specified in writing, the goods will be shipped with the means of transport considered most suitable by our company. The goods shall be checked by the receiver as soon as they reach their destination and **any claim for damages shall be filed directly with the carrier.**

Any manufacturing fault shall be immediately communicated by registered letter to our offices in Pieve di Soligo within 8 days after the goods have been received, and may also be communicated in other additional ways. By no means shall manufacturing defects entitle the purchaser to stop payments.

No goods shall be returned without our written authorization. Authorized returned goods shall be sent to us free port, together with a "returned goods" note showing the number and date of our original invoice related to such. 15% of total value shall be charged to our customer.

All Loran products are guaranteed for two years. The warranty shall no longer be valid if the product has been damaged or tampered with by the user.

Goods sold remain property of the seller until fully paid by the buyer. Should this not be the case, the seller shall be entitled to withdraw its goods at any time. In the event of any and all disputes, competent court shall exclusively be the court of Treviso (Italy).

Cette liste de prix est susceptible d'être modifiée à n'importe quel moment sans préavis. Les prix sont exprimés HT. **Les prix ne comprennent pas l'emballage.** L'installation est à la charge du client.

La commande, et toute modification éventuelle à celle-ci, devra être transmise par écrit et ne pourra être considérée acceptée qu'après l'envoi d'une confirmation écrite de notre part. Les délais fixés pour l'expédition ne constituent pas un terme de rigueur et ne pourront en aucun cas constituer prétexte pour retarder les paiements ou pour exiger un remboursement ou des dommages.

**La marchandise voyage aux risques et périls du client, franco départ-usine Loran srl de Pieve di Soligo (Italie):** en absence d'instructions écrites précises de la part du client, la marchandise sera envoyée par le moyen que nous jugerons le plus indiqué. **Les éventuelles réclamations concernant le transport devront être faites directement au transporteur au moment même de la livraison.**

Les éventuels défauts de fabrication devront être signalés, par lettre recommandée dans les 8 jours à compter de la date de réception de la marchandise, à Loran srl de Pieve di Soligo; et cela, même si déjà signalés au travers un autre moyen ou forme. De toute façon, il est entendu qu'une éventuelle réclamation ne donne en aucun cas le droit au client d'interrompre les paiements.

Aucun matériel ne pourra être rendu sans notre autorisation écrite. Les retours autorisés de marchandise devront nous parvenir franco de port et munis d'un bulletin de transport officiel indiquant entre autre le numéro et la date de la facture relative à la commande d'origine. Il est entendu que les marchandises rendues seront grevées de 15% pour cause de frais généraux.

Le matériel de Loran srl production bénéficie d'une garantie 2 ans, sujette à déchéance en cas de dégâts provoqués par l'utilisateur ou, de quelque manière, imputables à celui-ci.

Il est entendu que jusqu'au paiement complet par de l'acheteur de la marchandise vendue, celle-ci reste la propriété de l'entreprise vendeuse qui aura donc la faculté de retirer la marchandise à n'importe quel moment en cas de défaut, même partiel, de paiement. Il est entendu que tout différent ou litige entre les parties sera du ressort du tribunal de Treviso (Italie).

Diese Preisliste kann jederzeit und ohne Vorankündigung geändert werden. Die Preise verstehen sich zuzüglich Mehrwertsteuer. **Die Preise verstehen sich ausschließlich Verpackung.** Die Installation erfolgt auf Kosten des Kunden.

Der Auftrag und jede diesbezügliche Änderung hat schriftlich zu erfolgen und gilt erst nach unserer Auftragsbestätigung als angenommen. Die Lieferdaten sind nicht bindend und berechtigen keinesfalls zu Zahlungsverzögerungen oder Schadenersatzforderungen.

**Die Ware reist auf alleinige Gefahr des Auftraggebers ab unserem Firmensitz in Pieve di Soligo (Italien):** falls nicht anders schriftlich vereinbart, wird die Ware mit dem von uns als geeignet erachteten Transportmittel befördert. **Eventuelle Beanstandungen bezüglich des Transports sind bei der Anlieferung direkt dem Frachtführer zu melden.**

Fabrikationsfehler sind unserem Firmensitz in Pieve di Soligo innerhalb von 8 Tagen nach Erhalt der Ware per Einschreiben zu melden, auch wenn Sie vorher bereits in anderer Form mitgeteilt wurden. In jedem Fall berechtigen Sie den Kunden nicht zur Einstellung der Zahlungen.

Materialrückstellungen dürfen nur mit unserer schriftlichen Genehmigung erfolgen. Die genehmigten Rückstellungen haben Frachtfrei mit einem Transportschein zu erfolgen, auf dem die Rechnungsnummer und das Rechnungsdatum bezüglich der ursprünglichen Lieferung vermerkt sind, wobei 15% für allgemeine Kosten berechnet werden.

Das Material von Loran srl hat eine zweijährige Garantie, außer bei Schäden oder unsachgemäßer Behandlung durch den Anwender.

Die verkaufte Ware bleibt Eigentum des Verkäufers bis zur vollständigen Zahlung seitens des Käufers. Andernfalls behält sich der Verkäufer das Recht vor, die Ware jederzeit abzuholen. Für jegliche Streitigkeiten ist das Gericht von Treviso (Italien) zuständig.

La presente lista de precios puede ser modificada en cualquier momento y sin previo aviso. Los precios se consideran sin IVA. **El embalaje no está incluido en el precio.** La instalación está a cargo del cliente.

El pedido, y toda modificación del mismo, se deberá enviar por escrito y se considerará aceptado sólo después del envío de una confirmación por parte de Loran srl. Los plazos fijados para la expedición no son taxativos y en ningún caso podrán constituirse en un pretexto para retrasar el pago o pedir resarcimiento.

**La mercancía viaja por cuenta y riesgo del cliente, desde Loran srl en Pieve di Soligo (Italia).** Si no estuviera especificado por escrito, la mercancía será enviada por el medio de transporte considerado más conveniente por Loran srl. **Eventuales reclamos por el transporte se deberán realizar en el momento de la entrega directamente al transportista.**

Los defectos de fabricación deberán comunicarse mediante carta certificada a la sede de Loran srl de Pieve di Soligo, dentro de los 8 días a partir de la fecha de recepción de la mercancía, incluso si se comunicaron antes por otro medio. En cualquier caso esto no otorga derecho al cliente para suspender los pagos.

Ningún material podrá entregarse sin nuestra autorización escrita. Las entregas autorizadas deberán realizarse en puerto franco acompañadas por el documento de transporte que indique el número y la fecha de la factura correspondiente al suministro original y estarán gravados con 15% para gastos generales.

El material producido por Loran srl tiene una garantía de dos años, excepto eventuales daños o alteraciones causados por el usuario.

La mercancía vendida continuará perteneciendo al vendedor hasta el pago total por parte del comprador. En caso contrario el vendedor se reserva la facultad de retirarla en cualquier momento. Toda controversia será competencia de los tribunales de Treviso (Italia).



**Loran**  
*everyday passion*



**LORAN srl** • Via della Lira, 397 zona ind. • 31053 Pieve di Soligo • TV • Italy  
Tel. +39 0438 842603 • Fax +39 0438 980233 • [loran@loran.it](mailto:loran@loran.it) • [www.loran.it](http://www.loran.it)